

User's Manual

For

DB810A

Digital DC Servo Driver

Version 1.1

©2006 All Rights Reserved

Attention: Please read this manual carefully before using the driver!



The content in this manual has been carefully prepared and is believed to be accurate, but no responsibility is assumed for inaccuracies.

Leadshine reserves the right to make changes without further notice to any products herein to improve reliability, function or design. Leadshine does not assume any liability arising out of the application or use of any product or circuit described herein; neither does it convey any license under its patent rights of others.

Leadshine's general policy does not recommend the use of its products in life support or aircraft applications wherein a failure or malfunction of the product may directly threaten life or injury. According to Leadshine's terms and conditions of sales, the user of Leadshine's products in life support or aircraft applications assumes all risks of such use and indemnifies Leadshine against all damages.



Leadshine Technology Co., Ltd.

Floor 3, Block 2, Nanyou Tianan Industry Park, Nanshan Dist, Shenzhen, China

Tel: (86)755-26434369 Fax: (86)755-26402718

URL: www.leadshine.com E-Mail: sales@leadshine.com

©2006 by Leadshine Technology Company Limited.

All Rights Reserved

Table of Contents

1. Introduction, Features and Applications.....	1
Introduction	1
Features	1
Applications	1
2. Specifications and Operating Environment.....	2
Mechanical Specifications.....	2
Electrical Specifications	2
Operating Environment and Parameters.....	3
3. Connections.....	3
Connector Configuration.....	3
Control Signal Connections.....	4
Encoder Connections.....	5
Typical Connections	6
4. Servo Setup	8
Install Encoder.....	8
Prepare Power Supply	8
Regulated or Unregulated Power Supply	8
Selecting Supply Voltage.....	9
Prepare Controller	9
Initialize the DB810A	9
System Connections and Noise Prevention.....	10
Wire Gauge.....	10
Cable Routing.....	11
Twisted Wires.....	11
Cable Shielding	11
System Grounding.....	11

Power Supply Connection.....	12
5. Tuning the servo.....	12
Testing the servo.....	12
Tuning the Servo	13
Adjusting Gain and Damp Coefficients	15
6. Using Tips	20
Current Limit Setting	20
Alarm LED.....	21
Changing Default Motor Direction	22
ERR/RES Port.....	22
Maximum Pulse Input Frequency	23
APPENDIX.....	24
TWELVE MONTH LIMITED WARRANTY	24
EXCLUSIONS.....	24
OBTAINING WARRANTY SERVICE	24
WARRANTY LIMITATIONS	24
SHIPPING FAILED PRODUCT	25

1. Introduction, Features and Applications

Introduction

The DB810A is a digital DC servo driver developed with CPLD and high efficient MOSFET technologies. In position control, it's easy for the end users to change stepping drivers to the DB810A without changing control systems, because its input command is PUL/DIR signal, which is compatible with that of stepping drivers. In low power motion control applications, performances of DC servo systems using the DB810A are better than those of digital AC servo systems in velocity, precision, noise, stability, or at least as good as those of digital AC servo systems. However, the cost of the DB810A stays at the price line of stepping driver, namely far lower than those of AC servo drivers.

Features

- 18-80VDC, 0-20A, 20-400W
- PID feedback servo drive
- Feedback resolution $\times 4$ encoder line count
- Lock range ± 128 count following error
- Opto-isolated pulse and direction inputs (differential)
- Over-current and short-circuit protection
- Small size

Applications

Suitable for a wide range of equipments and instruments such as mini type engraving machines, jet-ink machines, etc. It performs better in equipments desired for low noise, high velocity and high precision.

2. Specifications and Operating Environment

Mechanical Specifications (unit:mm, 1 inch = 25.4 mm)

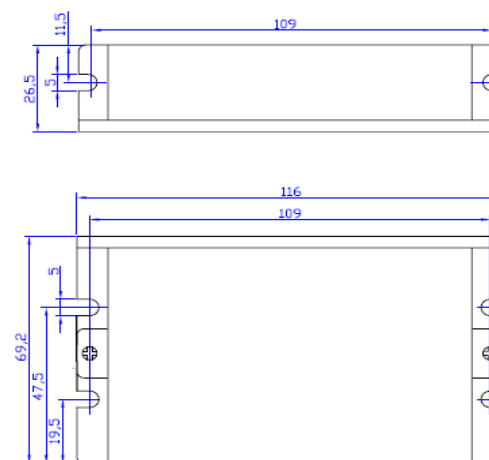

Figure 1: Mechanical specifications

Electrical Specifications ($T_j = 25^\circ\text{C}$)

Parameters	DB810A			
	Min.	Typical	Max.	Unit
Peak output current	0	-	20	A
Supply voltage	+18	-	+80	VDC
Logic signal current	7	10	15	mA
Pulse input frequency	0	-	500	KHz
Isolation resistance	500			MΩ
Current provided to encoder			50	mA

Operating Environment and Parameters

Cooling	Natural cooling or forced cooling	
Operating Environment	Environment	Avoid dust, oil fog and corrosive gases
	Ambient Temperature	0 °C – 50 °C
	Humidity	40 – 95%RH
	Vibration	5.9 m/s ² Max
Storage Temperature	-20 °C – +65 °C	
Weight	Approx. 130 grams (4.6 oz)	

3. Connections

Connector Configuration

General information

Pin	Signal	Descriptions
1	PUL+	Connect to positive pole of the pulse control signal.
2	PUL-	Connect to negative pole of the pulse control signal.
3	DIR+	Connect to positive pole of the direction control signal.
4	DIR-	Connect to negative pole of the direction control signal.
5	EB+	Connect to positive pole of the encoder channel B feedback signal.
6	EB-	Connect to negative pole of the encoder channel B feedback signal.
7	EA+	Connect to positive pole of the encoder channel A feedback signal.
8	EA-	Connect to negative pole of the encoder channel A feedback signal.
9	E +5V	Positive pole of the auxiliary power supply (50 mA (Max)).
10	EGND	Ground of the auxiliary power supply.
11	ERR/RES	Error alarm and reset/start port.
12	Motor+	Connect to positive pole of the DC servo motor.
13	Motor-	Connect to negative pole of the DC servo motor.
14	+18 TO 80VDC	Connect to positive pole of the +18 TO 80VDC power supply.
15	PGND	Connect to ground of the +18 TO 80VDC power supply.

More About PUL/DIR Signals

Pin Function	Details
PUL +	<u>Pulse signal</u> : This input represents pulse signal, effective for each rising edge; 4-5V when PUL-HIGH, 0-0.5V when PUL-LOW. For reliable response, pulse width should be longer than 1.2μs. Series connect resistors for current-limiting when +12V or +24V used.
PUL-	
DIR+	<u>Direction signal</u> : HIGH/LOW level signal, correlative to motor rotation direction. For reliable response, DIR must be ahead of PUL by 5μs at least.
DIR-	4-5V when DIR- HIGH, 0-0.5V when DIR-LOW. Series connect resistors for current-limiting when +12V or +24V used.

Control Signal Connections

The DB810A can accept differential and single-ended inputs (including open-collector and PNP output). The DB810A have 2 optically isolated logic inputs to accept line driver control signals. These inputs are isolated to minimize or eliminate electrical noises coupled onto the drive control signals. Recommend use line driver control signals to increase noise immunity in interference environments. In the following figures, connections to open-collector and differential control signals are illustrated.

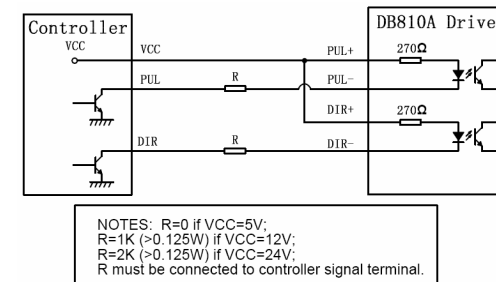

Figure 2: Connections to open-collector control signal (common-anode)

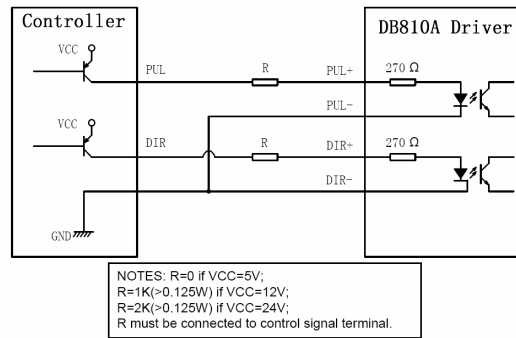

Figure 3: Connections to PNP signal (common-cathode)

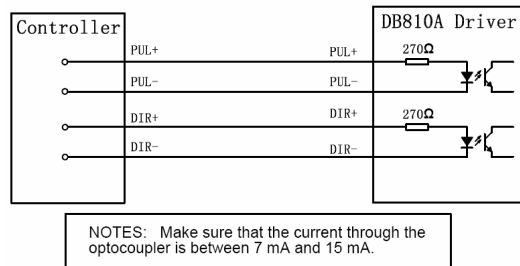

Figure 4: Connections to differential control signal

Encoder Connections

The DB810A can accept encoder input from either differential or single-ended encoders. Differential encoders are preferred due to their excellent noise immunity. The connections for a single-ended encoder are identical to a differential encoder except that no connections should be made to channel A- and channel B-. (The A- and B- lines are pulled up internally to +2.5V). Note that twisted-pair shielded cabling provides the best immunity in electrically noisy environments.

If the encoder drains less than 50mA, the DB810A can supply the encoder directly,

and connect it as Figure 5 or Figure 6. If the encoder drains more than 50mA, use an external DC supply and connect it as Figure 7 or Figure 8.

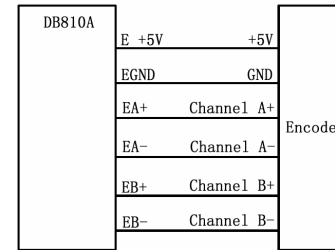

Figure 5: The DB810A supplies the differential encoder directly

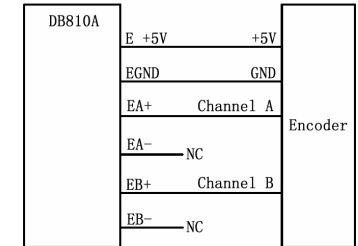

Figure 6: The DB810A supplies the single-ended encoder directly

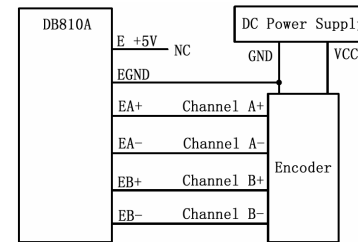

Figure 7: Using external DC power supply to supply the differential encoder

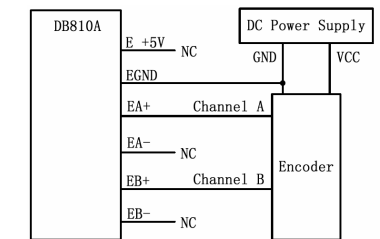

Figure 8: Using external DC power supply to supply the single-ended encoder

Typical Connections

Two typical connections of the DB810A are shown as Figure 9 and Figure 10. Please consult “Control Signal Connections” and “Encoder Connections” for more information about controller and encoder connections.

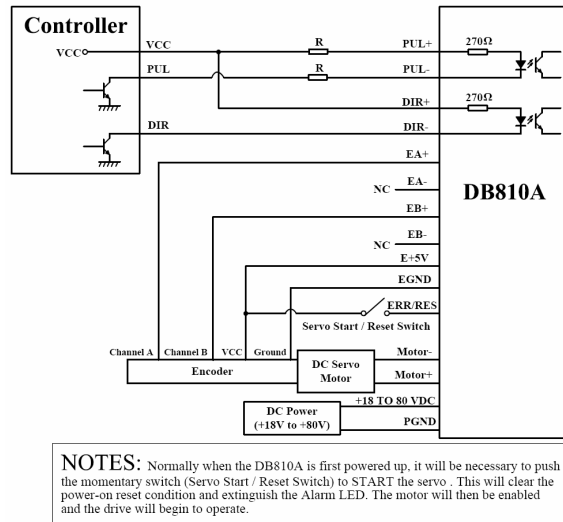

Figure 9: Typical connection (Open-collector control signal and single-ended encoder.)

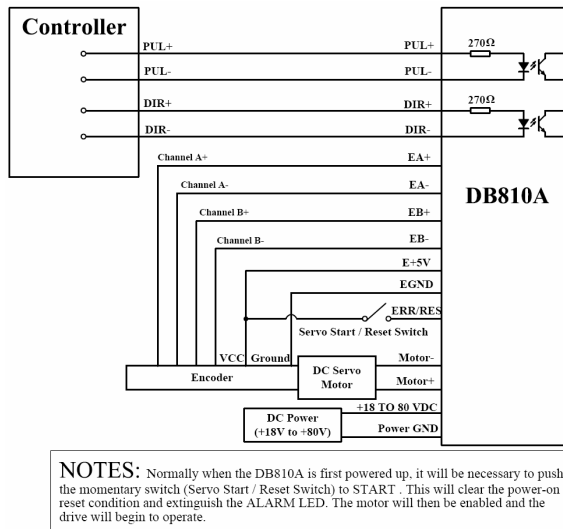

Figure 10: Typical connection (Differential control signal and differential encoder.)

4. Servo Setup

Before you start the servo, you can follow the below steps.

Install Encoder

If your motor has no encoder, you must have an encoder (more than 200 lines) properly mounted on the motor before you start. And please assemble the encoder according to its factory manual. **Here, we recommend use differential encoder again.** If you do have to use a single-ended encoder, please use shielded cables and separate encoder signal cable from interference sources, such as motor wires and power wires at least 5 cm.

Prepare Power Supply

Regulated or Unregulated Power Supply

Both regulated and unregulated power supplies can be used to supply the driver. However, unregulated power supplies are preferred due to their ability to withstand current surge. If regulated power supplies (such as most switching supplies.) are indeed used, it is important to have large current output rating to avoid problems like current clamp, for example using 4A supply for 3A motor-driver operation. On the other hand, if unregulated supply is used, one may use a power supply of lower current rating than that of motor (typically 50%~70% of motor current). The reason is that the driver draws current from the power supply capacitor of the unregulated supply only during the ON duration of the PWM cycle, but not during the OFF duration. Therefore, the average current withdrawn from power supply is considerably less than motor current. For example, two 3A motors can be well supplied by one power supply of 4A rating.

Selecting Supply Voltage

The DB810A can actually operate within +18V to +80VDC, including power input fluctuation and back EMF voltage generated by motor coils during motor shaft deceleration. The rated voltage of the motor is an important parameter when selecting supply voltage. Generally speaking, do not use a power supply voltage more than 5 volts of the rated voltage of the motor. Higher voltage may cause bigger motor vibration at lower speed, and it may also cause over-voltage protection or even driver damage.

Prepare Controller

Prepare a controller with pulse and direction signals.

Initialize the DB810A

The DB810A use three potentiometers to tune the current Limit, the Gain and the Damp. See Figure 11. These potentiometers are 10-turn potentiometers. CW increases value and CCW reduces value. Before going on, set the current Limit according to your motor’s Maximum Subtransient Current and usually current Limit is set to 1.2 times of motor’s Maximum Subtransient Current. The current Limit potentiometer can set the current Limit from 0A to 20A. Turn the Gain potentiometer fully off. Starting from off position, turn the Damp potentiometer CW to 2 turns.

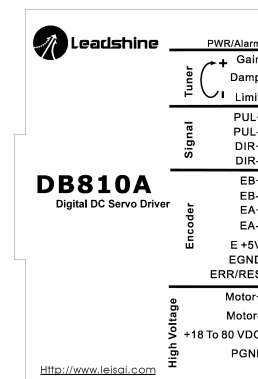

Figure 11: Sketch of the DB810A

System Connections and Noise Prevention

After finishing the above steps, you can connect your servo system. Before you start, make sure that the power is off. Check to see if the potentiometer settings are set according to the “Initialize the DB810A” section. Connect your system according to connection diagrams before, and pay attention to the following tips when wiring.

Wire Gauge

The smaller wire diameter (lower gauge), the higher impedance. Higher impedance wire will broadcast more noise than lower impedance wire. Therefore, when selecting the wire gauge, it is preferable to select lower gauge (i.e. larger diameter) wire. This recommendation becomes more critical as the cable length increases. Use the following table to select the appropriate wire size to use in your application.

Current (A)	Minimum wire size (AWG)
10	#20
15	#18
20	#16

Cable Routing

All content sensitive signal wires should be routed as far away from motor power wires and driver power wires as possible. Motor power and driver power wires are major sources of noise and can easily corrupt a nearby signal. This issue becomes increasingly important with longer motor power and driver power wires lengths.

Twisted Wires

Twisted wires effectively increasing noise immunity. The successive twists eliminate noise transients along the length of the cable. Both signal cables and power cables should be of the twisted and shielded type. Differential signal wires should be twisted as a pair. The combination of twisted pair wires and a differential signal significantly adds to noise immunity. Power wires should be twisted as a group along with the ground (or chassis) wire, if available.

Cable Shielding

All signal wires should be bundled and shielded separately from driver power and motor power wires. Power wires should also be bundled and shielded. When grounding a shield, the rule-of-thumb is to do so at the ‘source’ of power while leaving the other shield end open. For example, in the case of motor power wires, this would be the drive side. Ideally, twisted pairs should be individually shielded and isolated from the outer shield, which encompasses all wires within the cable. However, since this type of stringent shielding practice is often not required, typical cables do not provide isolation between inner and outer shields.

System Grounding

Good grounding practices help reduce the majority of noise present in a system. All common grounds within an isolated system should be tied to PE (protective earth) through a ‘SINGLE’ low resistance point. Avoiding repetitive links to PE creating

ground loops, which are a frequent source of noise. Central point grounding should also be applied to cable shielding; shields should be open on one end and grounded on the other. Close attention should also be given to chassis wires. For example, motors are typically supplied with a chassis wire. If this chassis wire is connected to PE, but the motor chassis itself is attached to the machine frame, which is also connected to PE, a ground loop will be created. Wires used for grounding should be of a heavy gauge and as short as possible. Unused wiring should also be grounded when safe to do so since wires left floating can act as large antennas, which contribute to EMI.

Power Supply Connection

NEVER connect power and ground in the wrong direction, because it will damage the DB810A driver. The distance between the DC power supply of the drive and the drive itself should be as short as possible since the cable between the two is a source of noise. When the power supply lines are longer than 50 cm, a 1000 μ F/100V electrolytic capacitor should be connected between the terminal “PGND” and the terminal “+18 TO 80VDC”. This capacitor stabilizes the voltage supplied to the drive as well as filters noise on the power supply line. Please note that the polarity can not be reversed.

It is recommended to have multiple drivers to share one power supply to reduce cost if the supply has enough capacity. To avoid cross interference, **DO NOT** daisy-chain the power supply input pins of the drivers. Instead, please connect them to power supply separately.

5. Tuning the servo

Testing the servo

You may wish to secure the motor so it can't jump off the bench. Turn on the power

supply, the green (Power) and red (Alarm) LED will light. After starting or resetting (pushing the servo starter (a momentary switch)) the servo, the red LED will turn off. You may hear the motor “singing”. It’s normal. The system is “zero-speed drift” . Change Gain and Damp coefficients, the motor “singing” will be changed.

If the motor jumps slightly and the red LED immediately turns on, then either the motor or the encoder is wired in reversal or the potentiometers are misadjusted. Check the potentiometer settings. If they are right then switch the motor or the encoder leads and try again. If it still doesn’t work after you followed all of the previous steps, please contact us at tech@leadshine.com.

If the red LED is off and the motor is normal, turn on controller or pulse source and ramp the speed up to see if the motor runs. It should run clockwise with a logical “1” on the direction input.

Tuning the Servo

A servo system is error-driven. The “Gain” of the system determines how hard the servo tries to reduce the error. A high-gain system can produce large correcting torques when the error is very small. A high gain is required if the output is to follow the input faithfully with minimal error.

A servo motor and its load both have inertia, which the servo amplifier must accelerate and decelerate while attempting to follow a change at the input. The presence of the inertia will tend to result in over-correction, with the system oscillating or “ringing” beyond either side of its target, for it has gotten into a UNDER DAMPED state. See Figure 12. This ringing must be damped, but too much damping will cause the response to be sluggish, namely cause the system into an OVER DAMPED state. When we tune a servo, we are trying to achieve the fastest response with little or no overshoot, namely get a CRITICALLY DAMPED response.

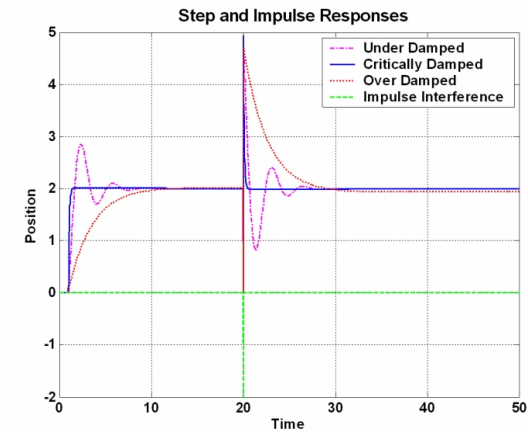

Figure 12: Step and impulse responses

As previous mention, the DB810A is a digital servo driver and its input command is PUL/DIR signal, in other words, step response is just exist in each step command signal. For each step command signal is a very small movement, so OVER SHOOT and SETTLING TIME between each step are very small, causing you hardly can see a step response such as Figure 12, even if the SET POINT is a very large quantity and the acceleration/deceleration is very high.

However, if you try to evaluate performances of the digital servo by investigating its position tracking-error or position following error, you may find it’s much easier than investigating its step response. The easiest way to get a tracking-error or position following error response is to induce an impulse load on the motor. See Figure 12 at “time 20”. And for evaluating servo performances, a test point (including TEST point and GND point) is set inside of the DB810A. See Figure 14. When there is no position error, the voltage should be 2.5V. The voltage between the TEST point and the GND point will decrease by 19.53 mV for every positive encoder count error, and the voltage between the TEST point and the GND point will increase by 19.53 mV for every negative encoder count error. Tune Damp and

Gain until performances of the servo are satisfying.

The first objective of tuning is to stabilize the system. If the system is unstable, then no matter how small the position set point or how little a disturbance (motor torque variation, load change, encoder noise, etc.) the system receives, the position error will increase continuously. In practice, when the system experiences instability, the actual position will oscillate in an exponentially diverging fashion as shown in the Figure 13 below. The ± 128 counts following error protect function of the DB810A will protect the system from large position error. $|\Delta Y(1)|/0.01953 = 2.5/0.01953 = 128$ counts. When you tune the servo with the load or for the not properly tuned parameters, this protection function will limits the oscillation and tells the controller or the user whether the system has reached the FOLLOWING ERROR LIMIT or not. Whether the system has reached the FOLLOWING ERROR LIMIT or not is reflected on whether the voltage between the TEST point and the GND point has reached +5V or 0V or not. See Figure 13. If the system reaches the limit, the Alarm LED will light and you have to reset/restart the DB810A to clear the Alarm.

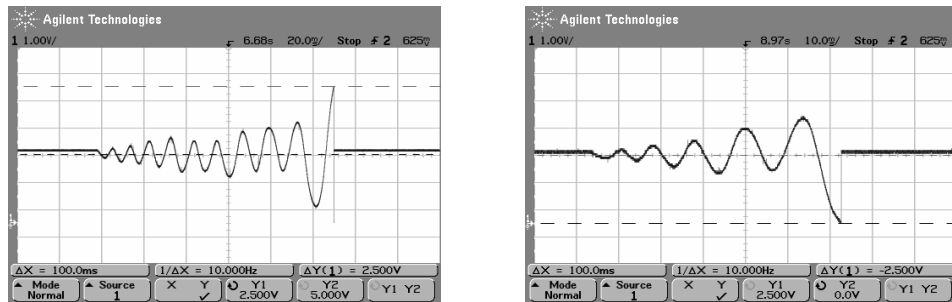

(a) Negative error limit

(b) Positive error limit

Figure 13: Position error limit

Adjusting Gain and Damp Coefficients

The following contents show how to improve the performances the of servo system

formed by the DB810A driver, the DCM50207-1000 motor and the DMC5400 controller through adjusting Gain and Damp coefficients. See Figure 14. We induce a disturbance by switching the direction input (use the Switch in Figure 14) while commanding a constant speed (8000p/s, namely 2 rpm) via the DMC5400.

We initially tuned the system to be an UNSTEADY system. Namely, the initial responses of the test system were like Figure 13 when given a small set point or small interference on the motor shaft. So the first objective of tuning is to stabilize the system. After increasing Damp or decreasing Gain, we got an impulse response shown as Figure 15. This is UNDER DAMPED response. The system has a slightly oscillatory response, causing a longer settling time (about 34.5ms). This oscillatory response is a cause of motor ringing too. Although the steady state position error of the DB810A servo system is usually can be eliminated to ± 1 count (see Figure 16.), here we assumed that the acceptable SETTLING BAND is $\pm(|\Delta Y(1)|/0.01953) = \pm(0.0563/0.01953) \approx \pm 3$ counts. The same as the following contents.

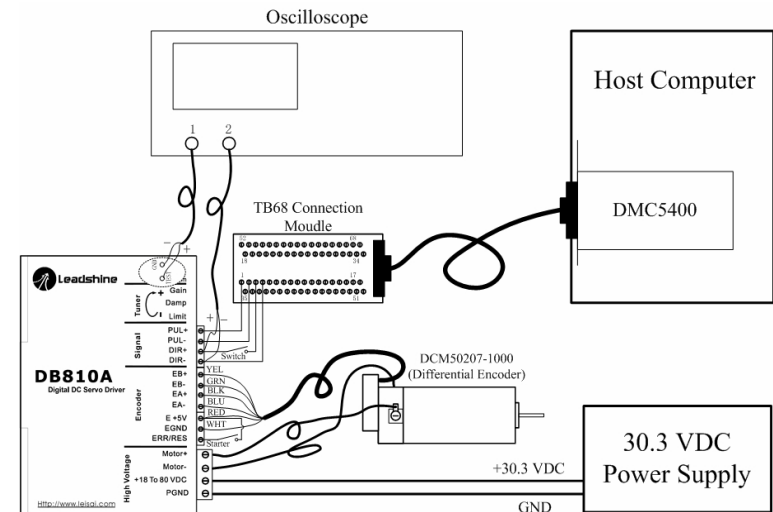
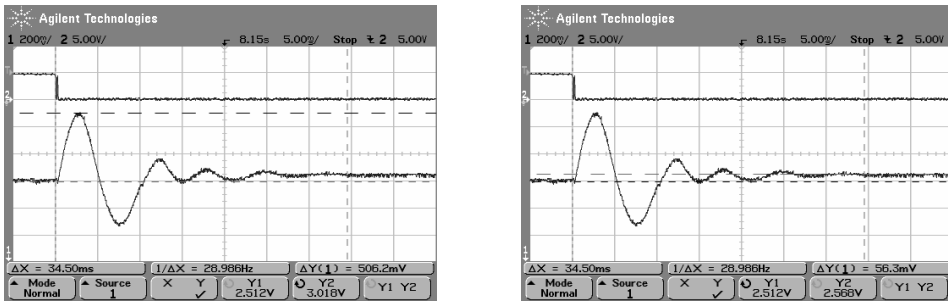

Figure 14: Test system

Please note that the MAX ERROR (see Figure 15 (a) $\Delta Y(1)$) and the SETTLING TIME (see Figure 15(b) ΔX) are related to the motion speed and the rotator inertia of the motor. Different rotation speed and motor rotator inertia, namely different impulse load and different motor you will get different results.



(a) Max error

(b) Steady state error

Figure 15: UNDER DAMPED response

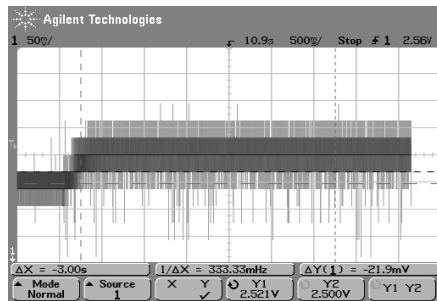

(a) Steady state position error detected by oscilloscope

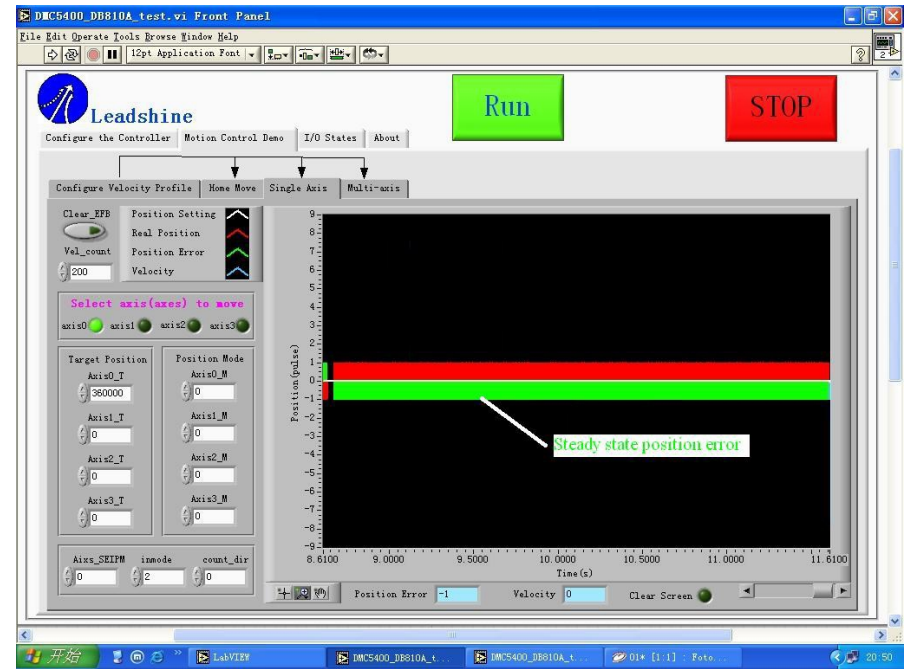

(b) Steady state position error detected by the DMC5400

Figure 16: Steady state position error

Remark: Figure 16 (b) is between X1 and X2 in Figure 16 (a); before X1 was a deceleration period.

When you encounter UNDER DAMPED response, you should decrease Gain or increase Damp to get a CRITICALLY DAMPED response, like Figure 17 below. Here the motor rapidly returns to the set point with little or no overshoot and the minimal SETTLING TIME. In Figure 17 (b) the SETTLING TIME is 13.30ms much faster than that of Figure 15 (b). When you get a CRITICALLY DAMPED response, you can stop tuning the servo.

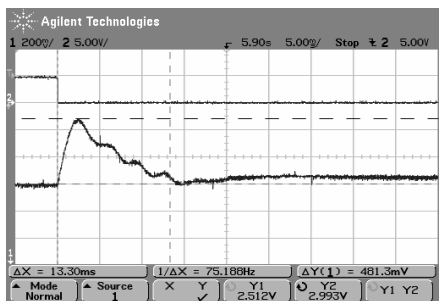

(a) Max error

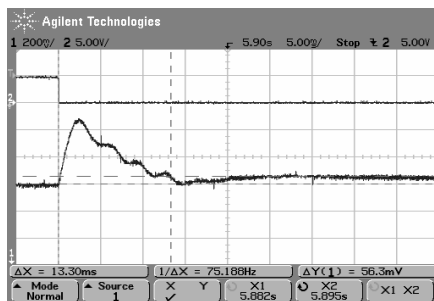

(b) Steady state error

Figure 17: CRITICALLY DAMPED response

However, if you increase Damp or decrease Gain too much, you may get an OVER DAMPED response like Figure 18. In this situation, the motor returns to SETTLING BAND with a long SETTLING TIME. In Figure 18 (b) the SETTLING TIME is 237ms, much longer than that of Figure 17 (b). When you encounter OVER DAMPED response, you should increase Gain or decrease Damp to get a CRITICALLY DAMPED response, like Figure 17.

Gain and Damp setting generally track each other. If you increase Gain, then increase Damp is needed as well to restore CRITICALLY DAMPED state. Note that different system you will get different curves of UNDER DAMPED, CRITICALLY DAMPED and OVER DAMPED responses. Tuning is the process of adjusting Gain and Damp coefficients to provide satisfying control for a particular system of motors and loads. It's not easy to get an ideally optimized performance or CRITICALLY DAMPED response like Figure 12. Remember tuning the servo is to get satisfying performances, getting the best performances of the servo is a time consuming work. So if the servo performance can meet your application requirements, then the easier tuning way the better. Just like if the performances of the products can meet your application requirements, then the cheaper the better.

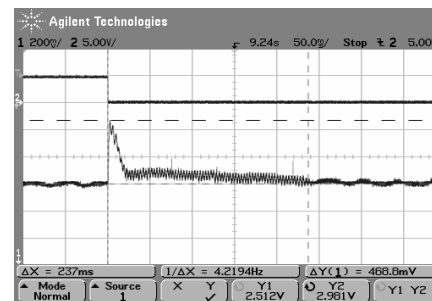

(a) Max error

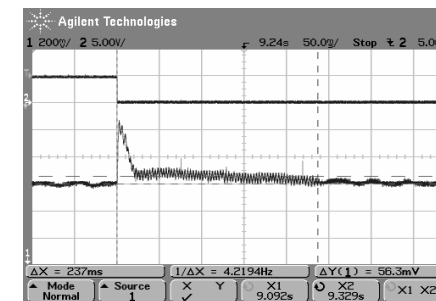

(b) Steady state error

Figure 18: OVER DAMPED response

Usually manually induce an interference load to the motor shaft or the load, and investigating or evaluating the response of the servo is also an easy way for an experience engineer to tune the servo.

Tuning servo systems formed by DB810A drivers can be summarized as the following rules:

1. If servo system is UNSTABLE, then the first objective of tuning is to stabilize the system. You can increase Damp or decrease Gain.
2. If servo system is UNDER DAMPED, then increase Damp or decrease Gain.
3. If servo system is CRITICALLY DAMPED, then stop tuning.
4. If servo system is OVER DAMPED, then decrease Damp or increase Gain.

6. Using Tips

Current Limit Setting

The current Limit potentiometer is adjustable from 0 A to 20 A. Normally the Limit potentiometer is set to Maximum Subtransient Current of the motor (default setting

is 20 A) unless you want to limit motor torque to a lower value.

When the torque demand due to load doesn't exceed current Limit setting, motor speed and position are unaffected by the current Limit setting. When the current Limit setting is active, the motor position may fall behind the command position because of insufficient torque.

Alarm LED

Normally when the DB810A is first powered up, it will be necessary to push the momentary switch to START servo for 2 seconds. This will clear the power-on reset condition and extinguish the Alarm LED. The motor will then be enabled and the drive will begin to operate.

After starting the servo, if a condition occurs that causes the DB810A to "fault out", such as the POSITION FOLLOWING ERROR reaches ± 128 counts, the ERR/RES terminal will go to "0", signaling the controller an error has occurred. The user must correct the problem that caused the fault and then restart or re-enable the DB810A.

At anytime the user can pull the ERR/RES to "0" to immediately halt the DB810A drive. See Figure 19. When the DB810A is in the "FAULT" state (Alarm LED lit), all switching action stops, all internal counters are reset and the motor freewheels and unpowered.

There are two conditions that will activate the protection function. One condition is a short circuit occurs or current exceeds current Limit setting.

The other condition is the POSITION FOLLOWING ERROR exceeds ± 128 counts causing servo-lock. This condition may have several causes:

- 1) The servo system is UNSTABLE or severely UNDER DAMPED, causing POSITION FOLLOWING ERROR limit occurs.
- 2) Excessive motor load due to acceleration or workload, the POSITION FOLLOWING ERROR exceeds ± 128 counts causing servo-lock.

- 3) The speed command in excess of what the motor can deliver, causing POSITION FOLLOWING ERROR occurs.
- 4) The current Limit is set too low, causing the motor can't output enough torque to follow the commanding and POSITION FOLLOWING ERROR occurs.
- 5) The power supply current is insufficient for the application, causing the motor can't output enough torque to follow the commanding and POSITION FOLLOWING ERROR occurs.
- 6) The motor is wired backwards, or is broken or disconnected.
- 7) Encoder failure or is wired backwards.

Changing Default Motor Direction

The DB810A will turn the motor in the CW direction when the direction input is "high" (logical "1"). If instead CCW is preferred, then:

- 1) Reverse the "motor +" and "motor -" leads.
- 2) Reverse the encoder "Channel A" and "Channel B" leads.

ERR/RES Port

This port functions as an error output and as a servo start/restart input. When first testing the DB810A or it is not necessary to read the state of the error output, ERR/RES port can be connected to E +5V port.

When the DB810A is functioning normally, the voltage on this terminal is +5VDC. The voltage on this terminal will go to 0VDC when the Alarm LED is lit. This output can be used to signal your controller that an error has occurred.

Figure 19 shows an external switch to clear an ERROR condition and START/RESET the DB810A, while still can read the state of the drive. It also includes an optional Alarm LED circuit if a remote state indication is desired.

Maximum Pulse Input Frequency

The highest frequency at which the drive can interpret encoder feedback. To convert this frequency to RPM, use the following formula:

$$RPM(\max) = \frac{(\text{Max Pulse Input Frequency}) \times 60}{(\text{Encoder Line Count}) \times 4}$$

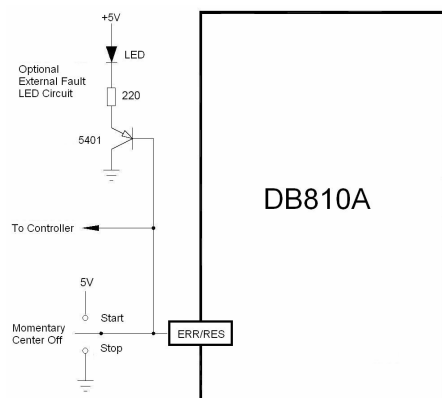

Figure 19: Alarm indication and start/stop circuit of the DB810A

APPENDIX

TWELVE MONTH LIMITED WARRANTY

Leadshine Technology Co., Ltd. warrants its products against defects in materials and workmanship for a period of 12 months from shipping date. During the warranty period, Leadshine will either, at its option, repair or replace products which proved to be defective.

EXCLUSIONS

The above warranty shall not apply to defects resulting from: improper or inadequate handling by customer; improper or inadequate customer wiring; unauthorized modification or misuse; or operation beyond the electrical specifications of the product and/or operation beyond environmental specifications for the product.

OBTAINING WARRANTY SERVICE

To obtain warranty service, a returned material authorization number (RMA) must be obtained from customer service at e-mail: tech@leadshine.com before returning product for service. Customer shall prepay shipping charges for products returned to Leadshine for warranty service, and Leadshine shall pay for return of products to customer.

WARRANTY LIMITATIONS

Leadshine makes no other warranty, either expressed or implied, with respect to the product. Leadshine specifically disclaims the implied warranties of merchantability and fitness for a particular purpose. Some jurisdictions do not allow limitations on how long and implied warranty lasts, so the above limitation or exclusion may not apply to you. However, any implied warranty of merchantability or fitness is limited

to the 12-month duration of this written warranty.

SHIPPING FAILED PRODUCT

If your product should fail during the warranty period, e-mail customer service at tech@leadshine.com to obtain a returned material authorization number (RMA) before returning product for service. Please include a written description of the problem along with contact name and address. Send failed product to distributor in your area or: Leadshine Technology Co., Ltd. Floor 3, Block 2, Tianan Industry Park, Nanshan Dist, Shenzhen, China. Also enclose information regarding the circumstances prior to product failure.