

## Routers

### Diamond-patterned



Types 620, 622, 624, 626

### Spiral-patterned



Types 720, 722, 724, 726

### Contour-finishing



Type 876

### 1-Flute router



Type 817, 818

### 2-Flute router



Types 826, 827, 828

### 3-Flute router



Type 836

### V-Groove cutter



Types 802, 803, 804, 806, 809

## Drills

### Ultra micro drills



Types 518, 218, 318, 418

### Standard drills



Type 530

### Spade type drills



Type 230

### Multilayer drills

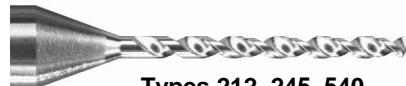

Types 212, 245, 540

### Microvia drills



Type 596

### Slot drills



Type 250

### Flex drills



Type 512

HPTec GmbH  
Im Karrer 6  
D-88214 Ravensburg  
Germany

Tel.: 0049 (0)751-7669-0  
Fax: 0049 (0)751-7669-139  
e-mail: sales@hptec.de  
www.hptec.de

**HPTEC**  
... more than just tools

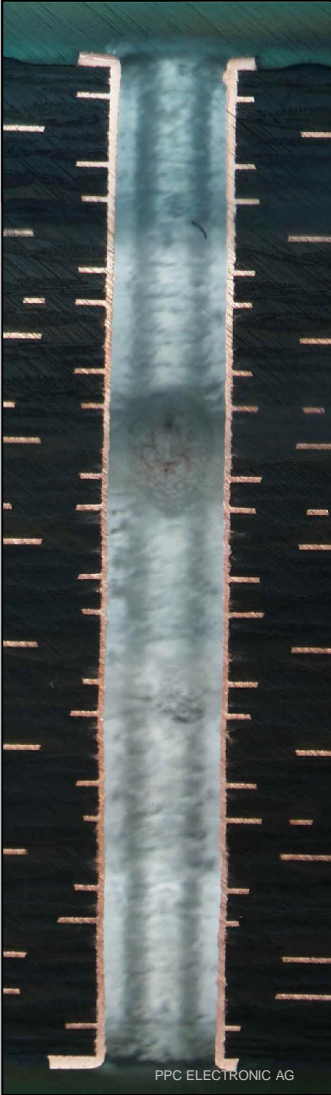
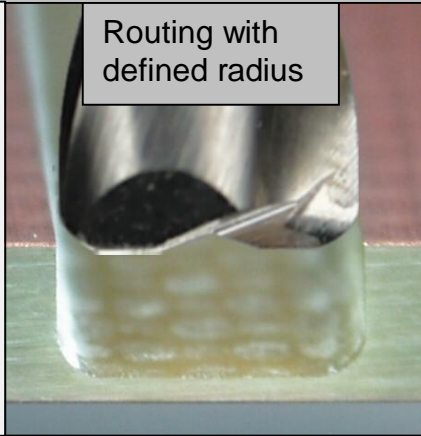
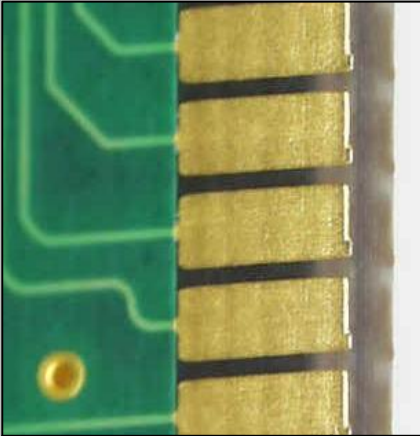

PPC ELECTRONIC AG

Newest technology in the Application Centers of



Application Center Ravensburg

Drilling spindle 300.000 rpm  
Routing spindle 125.000 rpm

Test Center Singapore

Drilling Spindle 200.000 rpm  
Routing Spindle 60.000 rpm

**Customized solutions!**  
**Your success!**

*Please ask your HPTec Partner for the best tools for your application.*

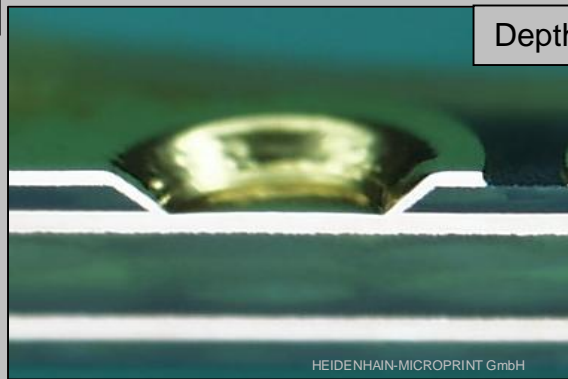
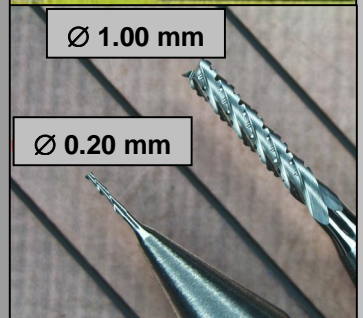
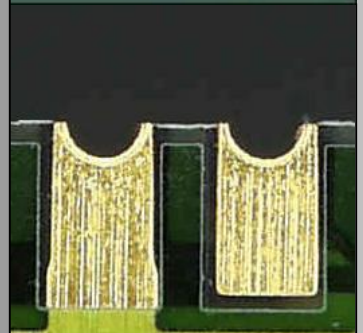
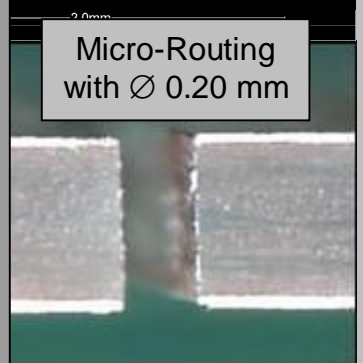

HEIDENHAIN-MICROPRINT GmbH

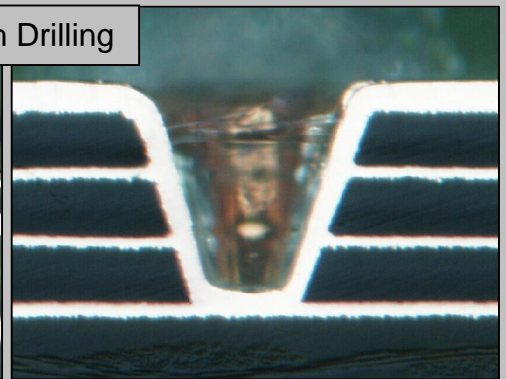

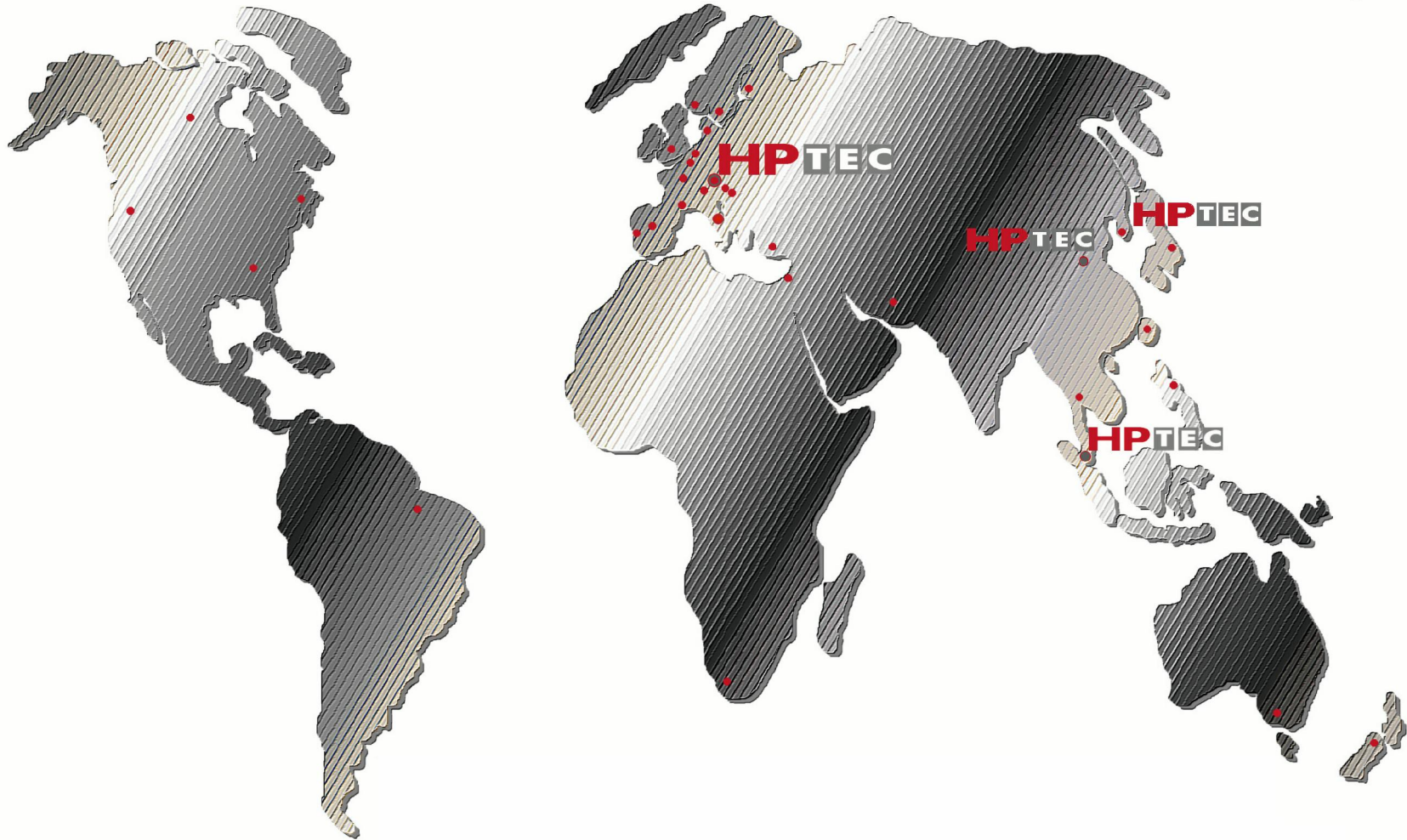

HPTec GmbH  
Im Karrer 6  
D-88214 Ravensburg, Germany  
Hotline: +49 751-7669-0  
Fax: +49 751-7669-139  
E-Mail: sales@hptec.de  
www.hptec.de

HPTec China (Kunshan) Co., Ltd.  
No. 88, ShuangMaRoad, Oumei Industry Park  
Dianshanhu, Kunshan, Jiangsu, P.R. China  
Hotline: +86 512 57488396  
Fax: +86 512 57488397  
E-Mail: huaweina@hptec.cn  
www.hptec.cn

HPTec Korea Co., Ltd.  
Room 502, 1784-6 Jungwang Dong, Kyunggi-Do  
Ko Shihung-City  
Hotline: +82 313199400  
Fax: +82 313194503  
E-Mail: msjung@hptec.co.kr  
www.hptec.co.kr

Hawera Precision Tec Pte. Ltd.  
11 Tuas Avenue 5  
SGP- Singapore 639337  
Hotline: +65 6863 1318  
Fax: +65 6863 1618  
E-Mail: hawera@multichem.com.sg  
www.hptec.com.sg

**ULTRAMICROBOHRER** Typen und Spirallängen  
**ULTRA MICRO DRILLS** Types and Flute Lengths



Ø [mm]	512	518 / 418*	218 / 318*	596
	Flex- bohrer	Standard- bohrer	Kopf- bohrer	Micro-Via- Bohrer
	Flex Drill	Standard Drill	Spade Type Drill	Micro-Via Drill
0,050		0,6*		
0,075		1,0*		Ø 0,12 x 0,5
0,100		1,5		
0,105		1,8	1,6 / 1,8	
0,110		1,8	1,8	
0,120		2,0	1,8 / 2,0	Ø 0,40 x 2,5
0,150	2,5	2,5	2,5	

Ø > 0,15 mm siehe Übersicht Micro-/Standardbohrer  
 Ø > 0,15 mm see survey Micro/Standard Drills

\* auf Anfrage  
 \* on request

418 / 318 Schaftdurchmesser = 2 mm  
 418 / 318 shank diameter = 2 mm

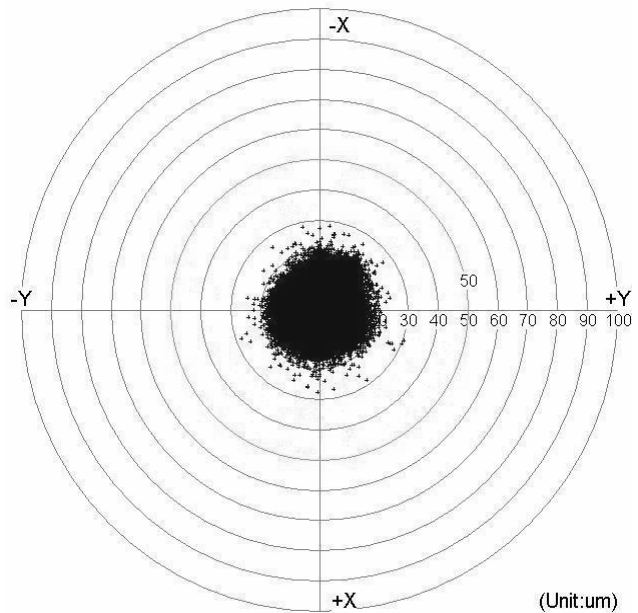
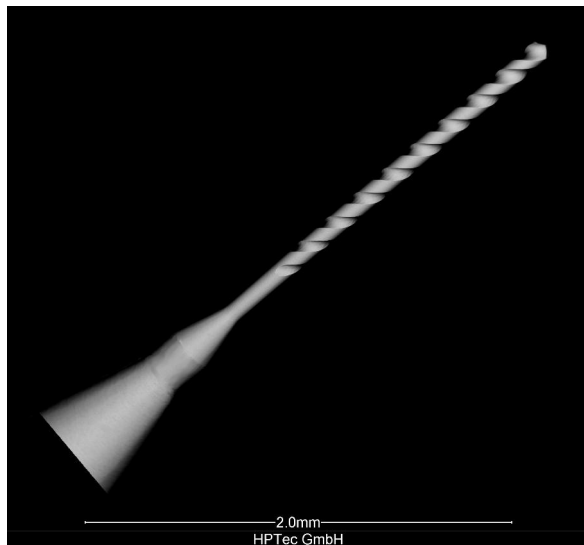

**BGA**

**BT-Material:** 0.1 mm 2 x 18 µm Cu  
**Stack height:** 6 up  
**Entry:** LE-800  
**Backup:** coated wood  
**Hits:** 3000  
**Parameter:** s = 200.000rpm  
 F = 35 mm/s  
 R = 250 mm/s

08.2008 - Technische Änderungen vorbehalten. / Subject to technical alterations.

Printed in Germany **HPTEC**

**MICRO-/STANDARDBOHRER** Typen und Spirallängen  
**MICRO STANDARD DRILLS** Types and Flute Lengths



	512	530	230	212	245	540	250
	Flex- bohrer	Standard- bohrer	Kopf- bohrer	Multilayer- bohrer			Langloch- bohrer
	Flex Drill	Standard Drill	Spade Type Drill	Multilayer Drill			Slot Drill
Ø [mm]	Ø ≤ 0,2 mm siehe Übersicht <b>ULTRAMICROBOHRER</b>						
	Ø ≤ 0,2 mm see survey <b>ULTRA MICRO DRILLS</b>						
	* auf Anfrage * on request						
0,20	3,5			3,5	3,5 / 4,0	3,2 / 4,0*	
0,25	3,5		3,5	4	4,0 / 4,5	3,2* / 4,0*	
0,30	5,5	5,5	5,5	5,5 / 6,5*	5,5 / 6,5*	5,5*	
0,35	*	5,5 / 7	5,5 / 7	5,5 / 7	7	5,5* / 7*	
0,40	*	5,5 / 7	5,5 / 7	5,5 / 7 / 8,5*	8,5	5,5* / 7*	
0,45	*	7	5,5* / 7	7 / 8,5*	8,5	7*	
0,50	*	7 / 8,5	7 / 8,5*	7 / 8,5	8,5	7*	5,5 / 7
0,55		7 / 8,5	7 / 8,5	8,5		7*	5,5 / 7
0,60		7 / 8,5	7 / 8,5	8,5		7*	5,5 / 7
0,65		7* / 8,5	7 / 8,5	8,5		7*	5,5 / 7
0,70		10,5	10			8,5*	7 / 8,5
0,75		10,5	10			8,5*	7 / 8,5
⋮							
0,85		10,5	10			8,5*	7 / 8,5
0,90		10,5	10			9,5*	7 / 8,5
0,95		10,5	10			9,5*	7 / 8,5
1,00		10,5	10			10,5*	8,5
⋮							
1,15		10,5	10			10,5*	8,5
1,20		10,5	10				8,5
1,25		10,5	10				8,5
⋮							
1,60		10,5	10				8,5
1,65		10,5	10*				8,5
⋮							
2,00		10,5	10*				8,5
⋮							
2,50		10,5					8,5
⋮							
3,175		10,5					
3,20		12					
⋮							
6,35		12					

08.2008 - Technische Änderungen vorbehalten. / Subject to technical alterations.

Printed in Germany **HPTEC**

**Spezifikation für Spiralbohrer 512/530/212/218/230/245/250/518/540**  
**Specification for drills** **08.08**

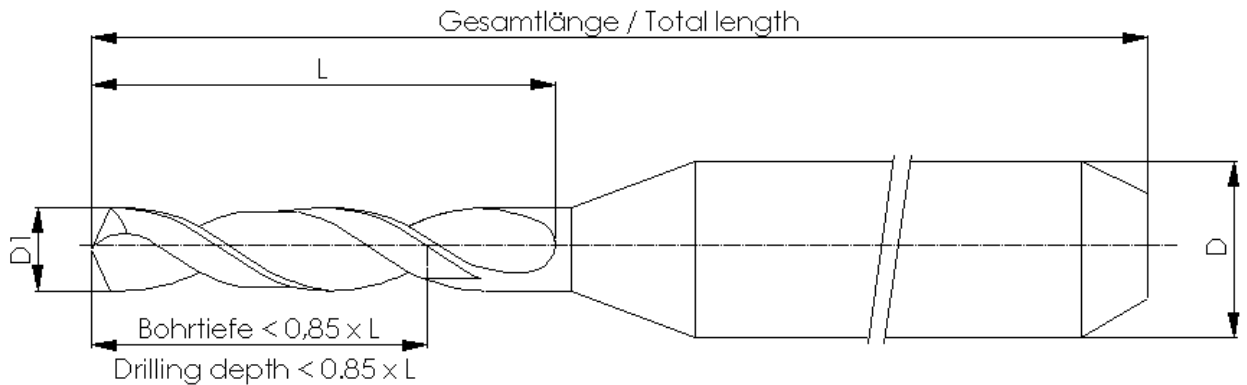

	0,05 < D <sub>1</sub> < D	D <sub>1</sub> > D
<b>Gesamtlänge / Total length</b>	<b>38,2 -0,2</b>	<b>38,2 -0,3</b>
<b>Spirallänge / Flute length</b>		
L ≤ 2	<b>+0,2 / -0,1</b>	
2 < L < 10	<b>+0,5 / 0</b>	
L ≥ 10	<b>+0,3 / -0,2</b>	<b>+0,4 / -0,3</b>
<b>Schneidenrauhtiefe R<sub>t</sub></b> <b>Roughness R<sub>t</sub></b>	<b>&lt; 0,003</b>	<b>&lt; 0,005</b>
<b>Schaft-/ shank Ø</b> D	<b>-0,001 / -0,007</b>	<b>-0,001 / -0,01</b>

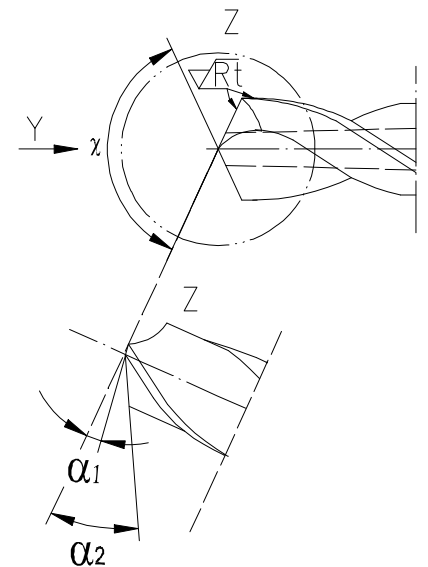

<b>Nenn-/ Nominal-Ø</b> D <sub>1</sub>	
0,05 ≤ 0,25	<b>+0,000 / +0,008</b>
0,26 ≤ 1,65	<b>+0,000 / -0,008</b>
1,66 - 3,175	<b>+0,000 / -0,012</b>
≥ 3,20	<b>+0,000 / -0,015</b>
Angaben / Data in [mm]	
<b>Spitzenwinkel δ</b> <b>Point angle δ</b>	
0,05 < D <sub>1</sub> ≤ 0,12	<b>130 -5</b>
0,12 < D <sub>1</sub> ≤ 0,20	<b>120 -5</b>
0,20 < D <sub>1</sub> ≤ 3,175	<b>130 -5</b>
D <sub>1</sub> > 3,175	<b>165 -5</b>
Typ 250	<b>150 -5</b>
<b>1. Freiwinkel α<sub>1</sub> /</b> <b>Primary face angle α<sub>1</sub></b>	
D <sub>1</sub> 0,05 – 0,20	<b>10 -3</b>
0,21 – 6,50	<b>15 -5</b>
<b>2. Freiwinkel α<sub>2</sub> /</b> <b>Secondary face angle α<sub>2</sub></b>	
D <sub>1</sub> 0,05 – 6,50	<b>30 -5</b>
Angaben / Data in [°]	

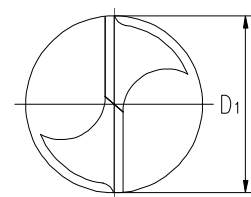

**Ideale Bohrerspitze /**  
**Ideal drill point**

## Survey of HPTEC drills / application fields

Type / design		Ø range [mm]	Double Sided – ML 4 layers	ML 6-8 layers	ML ≥ 10 layers	ML ≥ 70 µm copper	Back-panels	Flex / Flex-rigid	Polyimide	Teflon	Metal core ML	Thermount Aramide	PMMA / Plexiglas	Remark	
Standard drill	530	0.25 - 0.50	~	●	●	●	●	●	●	●	●	●	●	Universal drill for all standard applications	
		0.55 - 2.00	~	●	●	TM	TM	●	TM	TM	TM	●	●		
		2.00 - 7.00	~	~	~	~	~	●	●	●	●	●	●		
Multilayer drill	Spade type drill	230	0.25 - 2.00	~	~	●	●	●	●	~	●	~	●	Proved spade type drill for all multilayer boards	
		212	0.15 - 0.65	●	~	~	~	~	~	~	~	~	~	Highest demands on hole wall quality + chip transport	
		245	0.20 - 0.50	~	~	~	~	●	●	~	~	~	●	High performance drill. High stack heights. Excellent positioning accuracy	
	Standard	540	0.050 - 1.15	●	~	~	~	~	~	~	~	~	~	Highest demands on hole wall quality + chip transport	
Slot drill	Spade type drill	250	0.50 – 2.50	~	~	~	●	●	●	●	●	●	●	Drilling slots	
Flex drill	Standard	512	0.15 – 0.50	TM	TM	TM	TM	TM	~	TM	TM	TM	TM	TM	Excellent positioning accuracy, long tool life, more regrindings possible.
Micro Via drill	conical	596	0.075 - 0.40	~	~	~	~	~	●	●	●	●	~	Drill for conical blind via holes	

Key: ~ optimum  
 ● suitable  
 TM not recommendable



# 218

# 318

**ULTRAMICROBOHRER**  
Kopfbohrergeometrie  
für hochdrehende Spindeln  
Anwendung/Vorteile:

- BGA / HDI
- höchste Stabilität
- höchste Bohrgenauigkeit

**ULTRA MICRO DRILL**  
spade type version  
for high speed spindles  
Application/Advantages:

- BGA / HDI
- best stability
- best accuracy

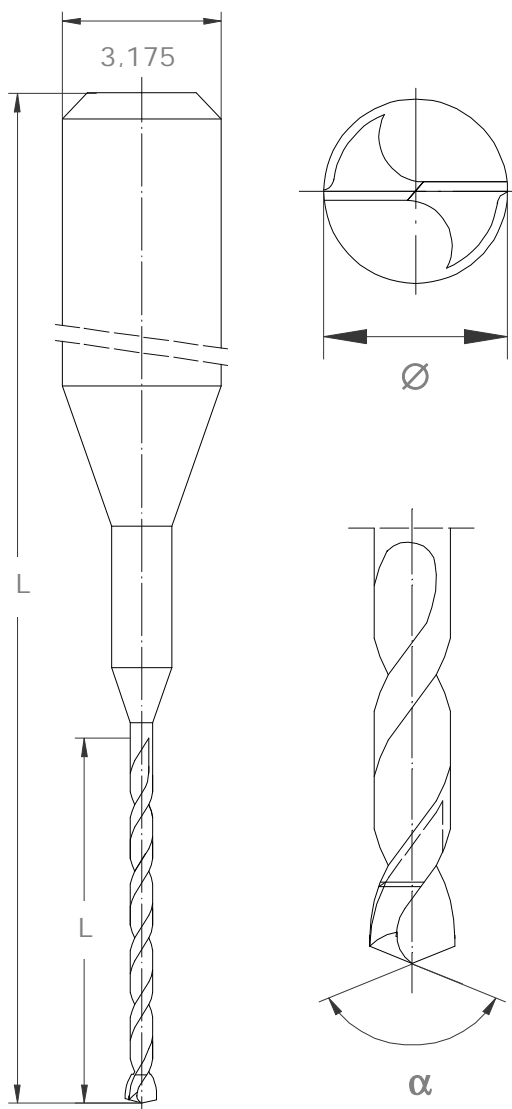

218				
Ø [ mm ]	L [ mm ]			
	1,6	1,8	2,0	2,5
0,105	x	x		
0,110		x		
0,120		x	x	
0,150				x

Auf Anfrage Typ 318 mit  
Schaftdurchmesser 2,0 mm /  
Gesamtlänge 32 mm erhältlich.

On request type 318 with  
shank diameter 2,0 mm /  
total length 32 mm available.

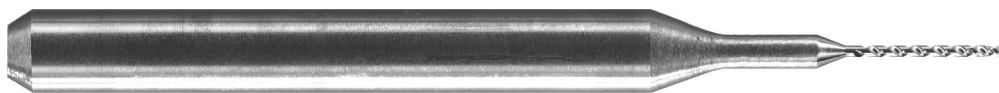

# 212

Multilayerbohrer, Kopfbohrergeometrie  
Anwendung/Vorteile:

- Bohren von hochlagigen Multilayern
- Verbesserung der Lochqualität

Multilayer drill, spade type version.  
Application/Advantages:

- drilling of high layer boards
- improvement of hole quality

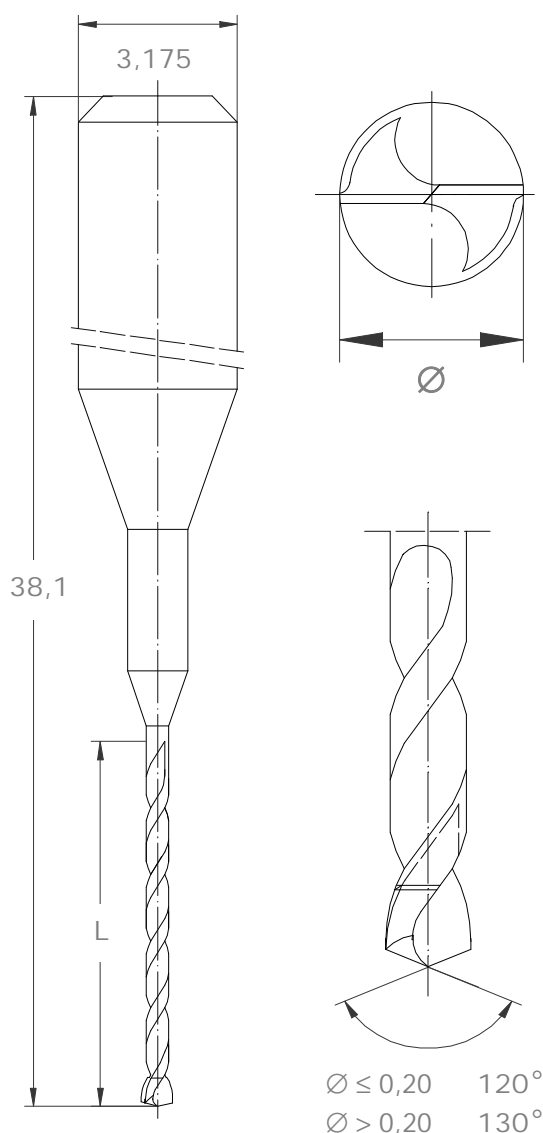

$\varnothing \leq 0,20$      $120^\circ$   
 $\varnothing > 0,20$      $130^\circ$

212	
Ø [ mm ]	L [ mm ]
	3,5 4,0 5,5 6,5 7,0 8,5
0,20	x
0,25	x
0,30	x x*
0,35	x x
0,40	x x x*
0,45	x x*
0,50	x x
0,55	x
0,60	x
0,65	x

\* auf Anfrage    \* on request

\* auf Anfrage    \* on request

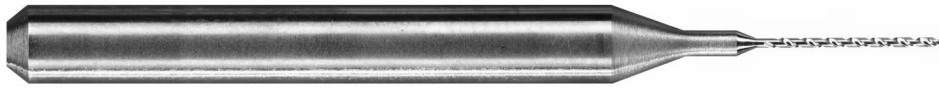

# 230

## Kopfbohrer

### Anwendung/Vorteile:

- Bohren von anspruchsvollen Multilayern
- Die optimierte Geometrie erzeugt eine sehr gute Lochqualität bei geringem Bohrerverlauf.

## Spade type drill

### Application/Advantages:

- drilling of high-quality multi-layer boards
- the optimised undercut geometry gives an excellent hole quality by less drill deflection

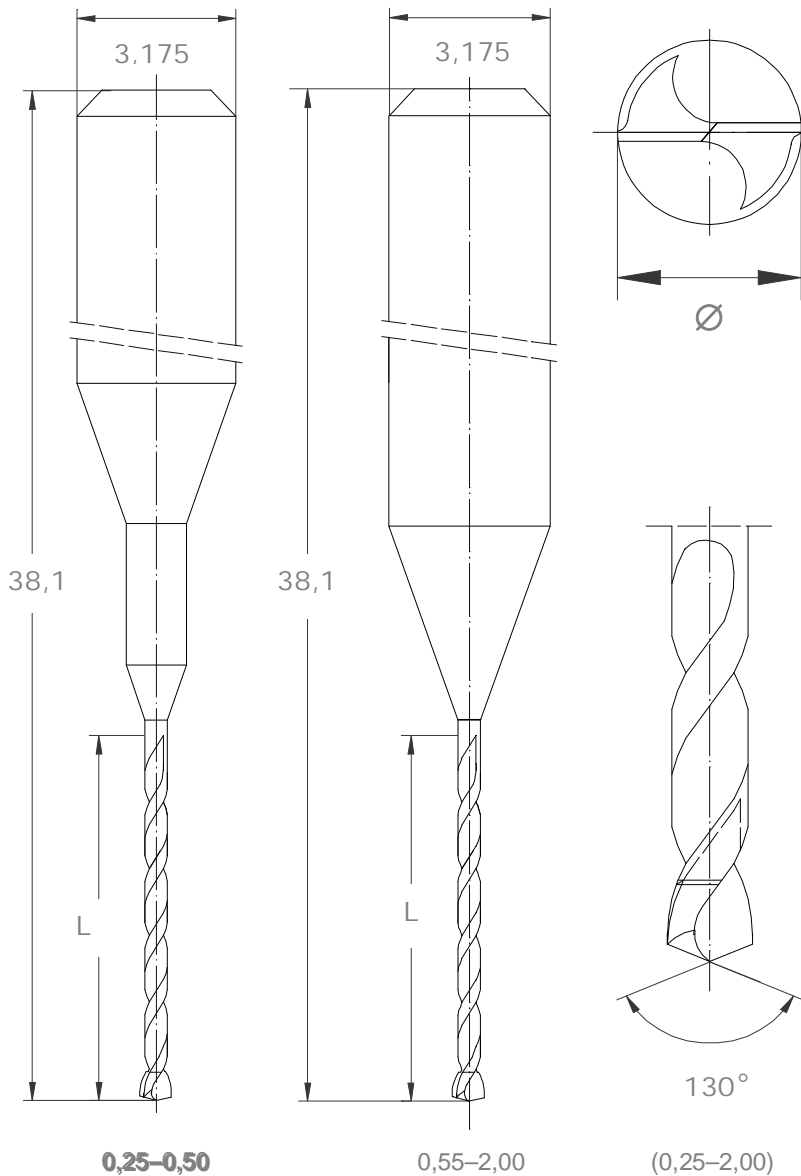

230				
Ø [ mm ]	L [ mm ]			
	3,5	5,5	7,0	8,5
0,25	x			
0,30		x		
0,35		x	x	
0,40		x	x	
0,45		x*	x	
0,50			x	x*
0,55			x	x
0,60			x	x
0,65			x	x

Ø [ mm ]	L [ mm ]
	10,0
0,70	x
0,75	x
0,80	x
⋮	⋮
1,60	x
1,65	x*
⋮	⋮
2,00	x*

\* auf Anfrage \* on request

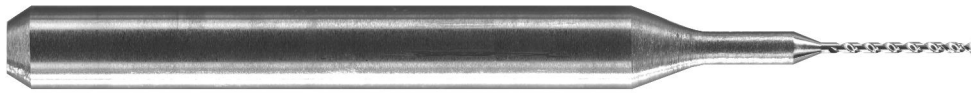

# 245

Multilayerbohrer, Kopfbohrergeometrie  
Anwendung/Vorteile:

- Hoch produktive Bearbeitung von Multilayern.
- Verbesserung des Bohrerverlaufs durch neue Geometrie.

Multilayer drill, spade type version.  
Application/Advantages:

- High performance drilling of multilayer boards
- BT-material / BGA application
- High demand on tool deviation
- High stack

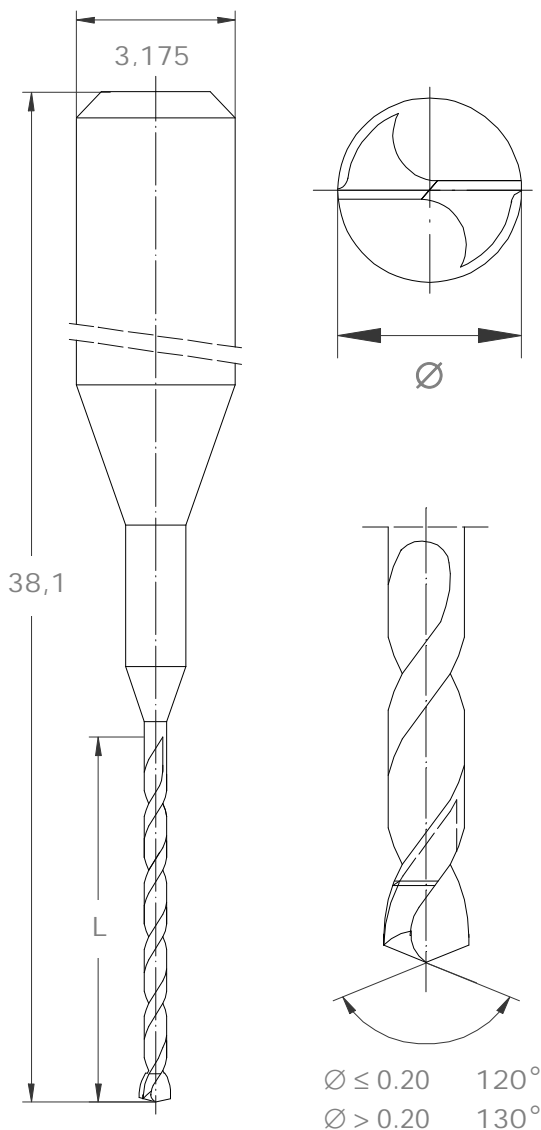

$\varnothing \leq 0,20$  120°  
 $\varnothing > 0,20$  130°

245								
Ø [ mm ]	L [ mm ]							
	3,5	4,0	4,5	5,5	6,5	7,0	8,5	
0,20	x	x						
0,25		x	x					
0,30				x	x*			
0,35						x		
0,40							x	
0,45							x	
0,50							x	

\* auf Anfrage

\* on request



# 250

## Langlochbohrer

Anwendung:

- Bohren (Nippeln) von Langlöchern und Schlitzen

## Slot drill

Application:

- drilling slots

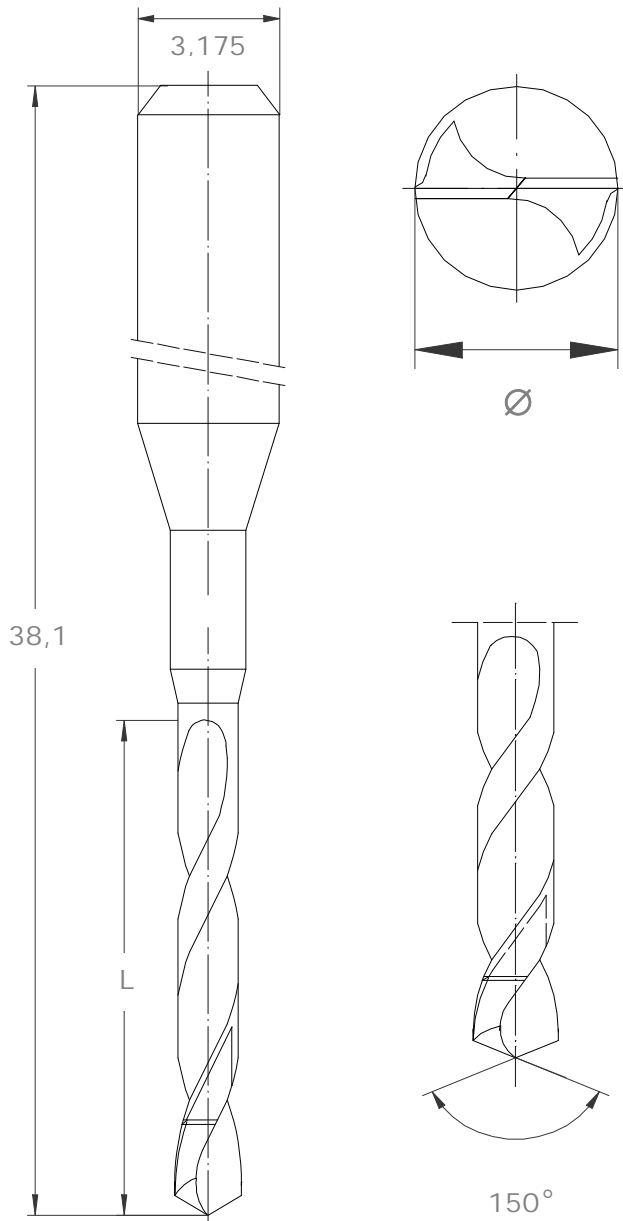

250			
Ø [ mm ]	L [ mm ]		
	5,5	7,0	8,5
0,50	x	x	
0,55	x	x	
0,60	x	x	
0,65	x	x	
0,70		x	x
0,75		x	x
0,80		x	x
0,85		x	x
0,90		x	x
0,95		x	x
1,00			x
⋮			⋮
1,25			x
1,30			x
⋮			⋮
2,50			x



# 518 418

### ULTRAMICROBOHRER

Standardbohrergeometrie  
für hochdrehende Spindeln  
Anwendung/Vorteile:

- BGA / HDI
- höchste Stabilität
- höchste Bohrgenauigkeit

### ULTRA MICRO DRILL

standard geometry  
for high speed spindles  
Application/Advantages:

- BGA / HDI
- best stability
- best accuracy

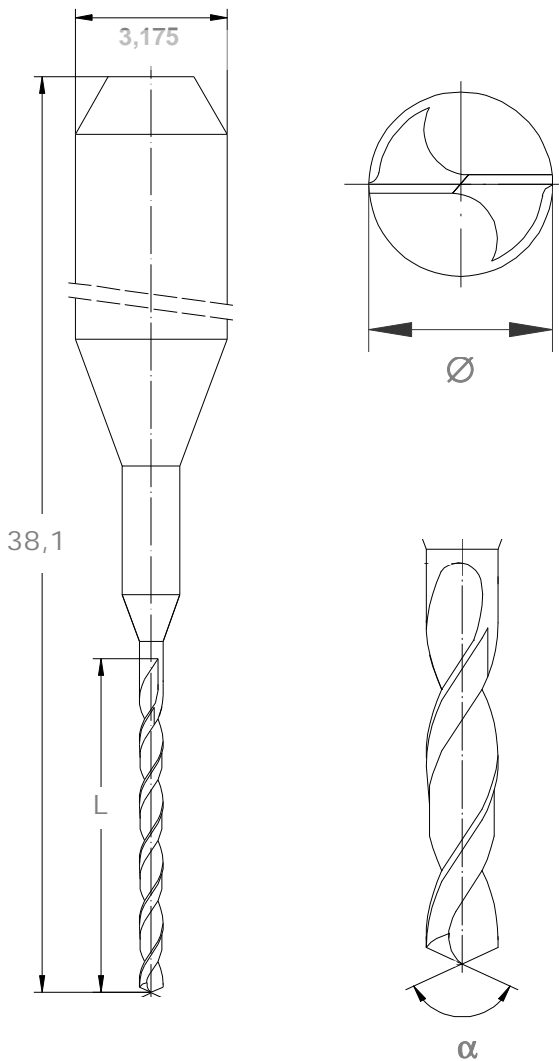

518	
Ø [ mm ]	L [ mm ]
	0,6 1,0 1,5 1,8 2,0 2,5
0,050	x*
0,075	x*
0,100	x
0,105	x
0,110	x
0,120	x
0,150	x

\* auf Anfrage \* on request

Auf Anfrage Typ 418 mit  
Schaftdurchmesser 2,0 mm /  
Gesamtlänge 32 mm erhältlich.

On request type 418 with  
shank diameter 2,0 mm /  
total length 32 mm available.

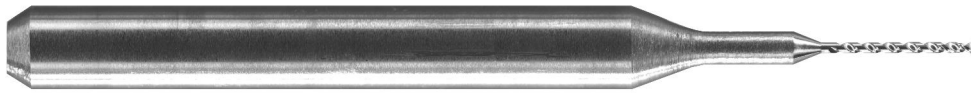

# 512

## Flexbohrer

### Anwendung/Vorteile:

- Hoch produktive Bearbeitung von flexiblen und starr-flexiblen Multilayern.
- Optimale Bohrerlochqualität durch neue Geometrie.
- Reduzierung von Nagelkopfbildung und Grat.

## Flex drill

### Application/Advantages:

- Drilling of flex and flex rigid boards
- Improvement of hole quality
- Reduction of nail heading

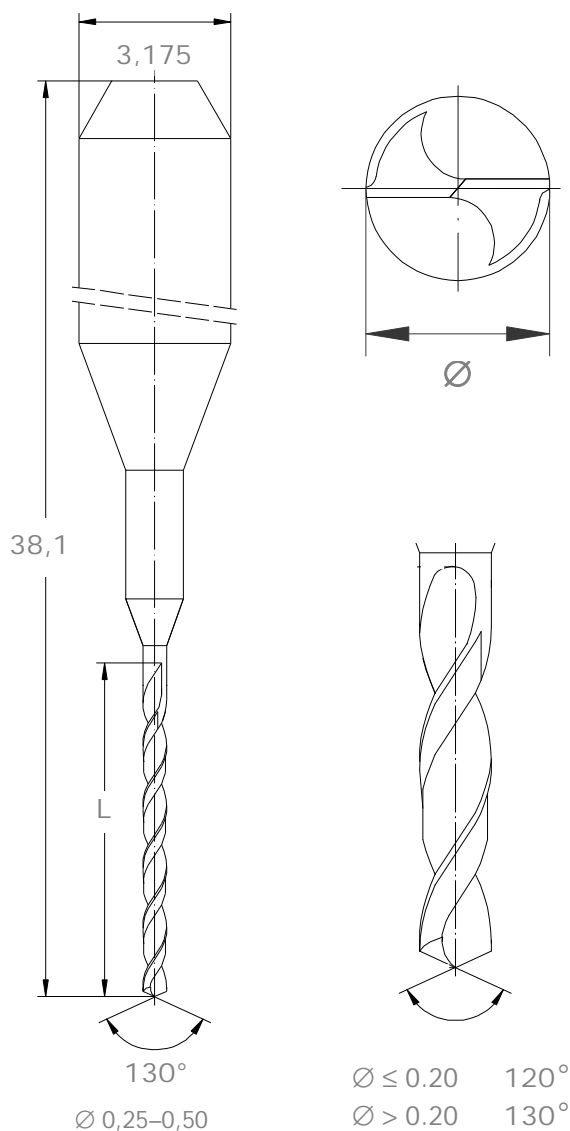

512		
Ø [ mm ]	L [ mm ]	
	2,5	3,5 5,5
0,15	x	
0,20	x	
0,25	x	
0,30	x	
0,35*		
0,40*		
0,45*		
0,50*		

\* weitere Durchmesser und Spirallängen auf Anfrage

\* other diameters and flute lengths on request



# 530

Spiralbohrer

Anwendung:

- für alle Standardprodukte

Standard drill

Application:

- for all standard products

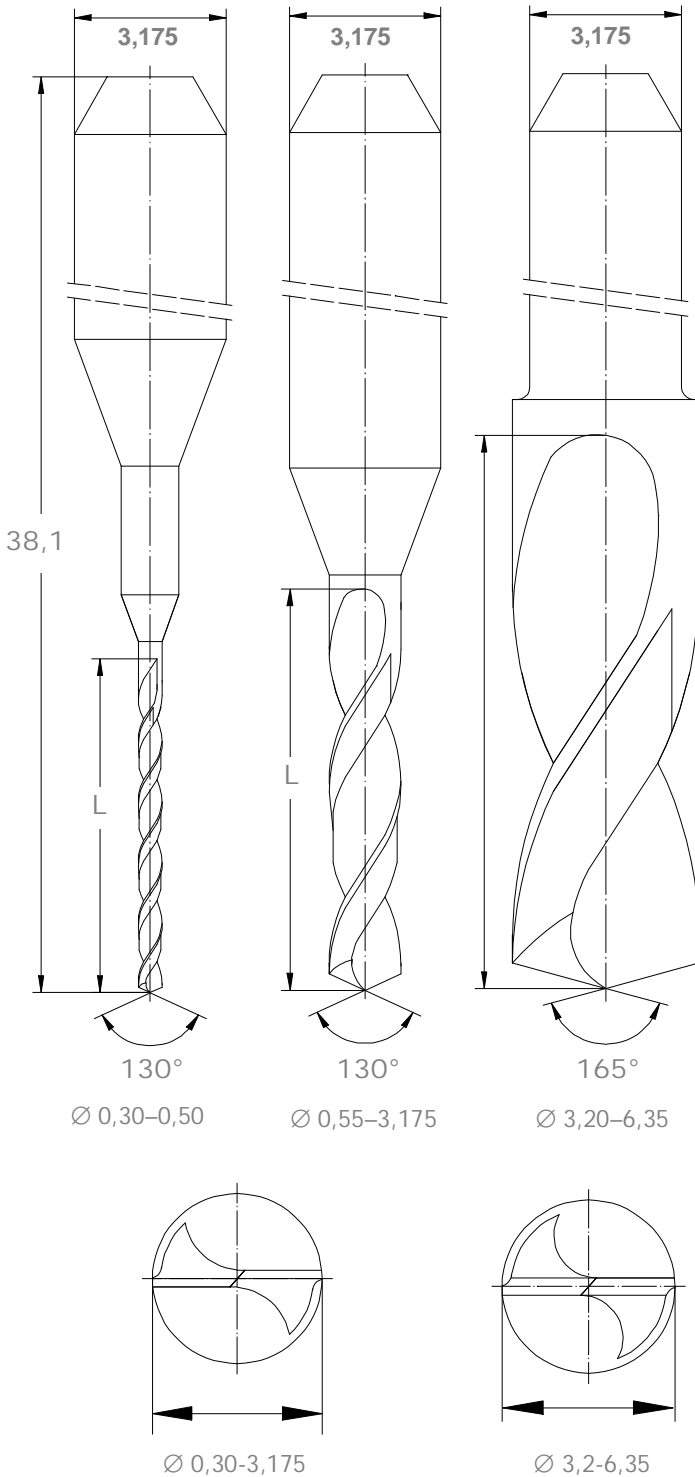

530		
Ø [ mm ]	L [ mm ]	
	5,5	7,0 8,5
0,30	x	
0,35	x	x
0,40	x	x
0,45	x	
0,50	x	x
0,55	x	x
0,60	x	x
0,65	x*	x

Ø [ mm ]	L [ mm ]	
	10,5	12
0,70	x	
0,75	x	
0,80	x	
⋮	⋮	
3,15	x	
3,175	x	
3,20	x	
3,25	x	
⋮	⋮	
6,35	x	

\* auf Anfrage \* on request

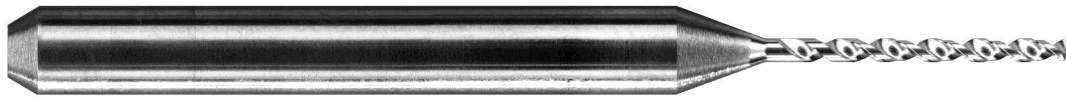

# 540

## Multilayerbohrer

### Anwendung/Vorteile:

- Bohren von hochlagigen / dicken Multilayern
- Verbesserung der Bohrlochqualität

## Multilayer drill

### Application/Advantages:

- drilling of high layer boards
- drilling of thick panels
- improvement of hole quality

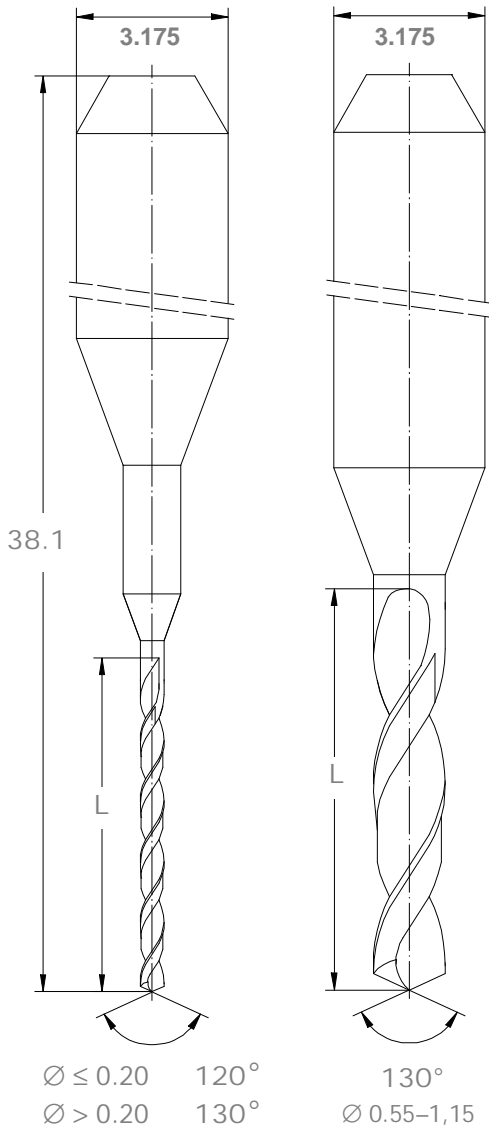

540	
Ø [ mm ]	L [ mm ]
	3,2 4,0 5,5 7,0
0,20	x x*
0,25	x* x*
0,30	x*
0,35	x* x*
0,40	x* x*
0,45	x*
0,50	x*

540				
Ø [ mm ]	L [ mm ]			
	7,0	8,5	9,5	10,5
0,55	x*			
0,60	x*			
0,65	x*			
0,70		x*		
0,75		x*		
0,80		x*		
0,85		x*		
0,90			x*	
0,95			x*	
1,00				x*
1,05				x*
1,10				x*
1,15				x*

\* auf Anfrage \* on request



# 596

Microvia Bohrer mit konischem Außendurchmesser

Anwendung/Vorteile:

- Bohren von Microvias (Sacklöchern)
- sehr gute Lochqualität und Positionsgenauigkeit

Microvia drill with tapered outer diameter.

Application/Advantages:

- drilling of microvias (blind holes)
- excellent hole quality and high position accuracy

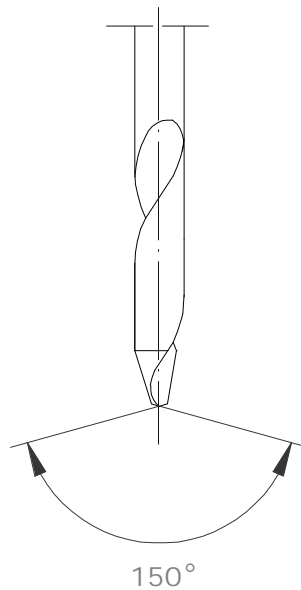
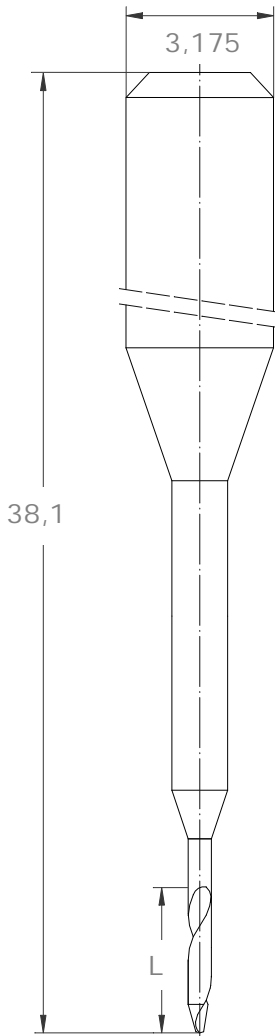

596		
Ø [ mm ]	L [ mm ]	
		0,5
0,12	x	
0,40		x

Bemerkung: andere Durchmesser auf Anfrage  
Remark: other diameters on request

Typ 596 Ø 0,12  
Maximale Bohrtiefe  
120 µm.

Type 596 Ø 0.12  
Maximum drilling  
depth 120 µm.

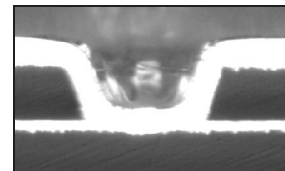

Mechanisch gebohrtes Sackloch auf die erste Innenlage.

Mechanical drilled microvias to the first inner layer.

Typ 596 Ø 0,4  
Maximale Bohrtiefe  
400 µm.

Type 596 Ø 0.4  
Maximum drilling  
depth 400 µm.

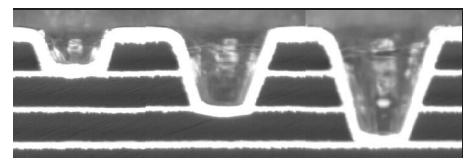

Mechanisch gebohrte Sacklöcher auf drei Innenlagen.

Mechanical drilled microvias to three inner layers.

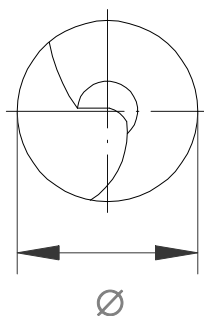





HPTec GmbH  
Im Karrer 6  
D-88214 Ravensburg  
Germany

Tel.: +49 (0)751-7669-0  
Fax: +49 (0)751-7669-139  
E-Mail: sales@hptec.de  
www.hptec.de

# HPTEC

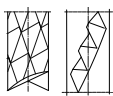
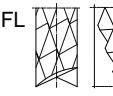
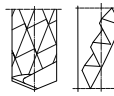
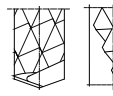
## Standardfräser Übersicht / Survey of Standard Routers

Ø in [mm]	626 620*		726 724*		818 817		depth router 826 828		PCB depth router 827	836	876*	Ritzstichel								
	diamantverzahnt diamond-patterned teeth		spiralverzahnt spiral-patterned teeth		1-Schneider 1-flute		2-Schneider 2-flute			3-Schneider 3-flute	Schlichtfräser finishing router	V-groove cutter point angle								
0,20								0,7	x*	x*						<b>802</b>	<b>803</b>	<b>804</b>	<b>806</b>	<b>809</b>
0,25								1	x*	x*						point angle				
0,3								1	x*	x*						30°	30°	45°	60°	90°
0,4						1,5	x	1,5	x*	x*										
0,5			3	x	3	x	3	x	x											
0,6			3	x	3	x	3	x	x	x*										
0,7			3,5	x	3	x	3	x	x	x*										
0,8			5	x	3	x	3	x	x	x*										
0,9			5	x	3	x	3	x	x	x*										
1,0	7	x	x*	7 / 8,5*	x	x*	3	x	x	x	5	x*								
1,1	7	x		7 / 8,5*	x		3	x*	x*	5	x*									
1,2	7	x	x*	7 / 8,5*	x	x*	4	x	x	x	5	x*								
1,3	7	x		7 / 8,5*	x		4	x*	x*	5	x*									
1,4	7	x		7 / 8,5*	x		4	x	x*	5	x*									
1,5	8	x		8,5	x		4	x	x*	6	x*									
1,6	8	x	x*	8,5	x	x*	5	x	x	x	7	x*	7	x*						
1,7	8	x		8,5	x		5	x*	x*	6	x*									
1,8	8	x		8,5	x		5	x*	x*	6	x*									
1,9	8	x		8,5	x		5	x*	x*	6	x*									
2,0	8 / 10	x	x*	9	x	x*	8	x	x	x	9	x*	7	x*	x	x	x			
2,1	8	x		9*	x			8	x	x	x*									
2,2	8	x		9*	x			8	x	x	x*									
2,3	8	x		9*	x			8	x	x	x*									
2,4	8 / 10	x	x*	9	x	x*	8	x	x	x	9	x*	7	x*					x	
2,5	8	x		9	x			8	x	x	x*									
3,0	10*	x		9	x		9	x	x	x										
3,175	10*	x		9	x		9	x*	x*	10	x									x

626*/726*/826*/836*/876*	620*/720*	624*/724*	624*/724*	622*/722*	F = Fischeschwanz / fishtail cut	817/818/827/828	spitz / pointed	flach / flat
FR 	FL 	BR 		BL 	B = Bohrspitze / drill point	flacher Stirnanschliff	<b>803/804</b>	<b>802</b>
					R = rechtsspiralig / up cut	flatt end cut	<b>806/809</b>	
					L = linksspiralig / down cut	rechtsspiralig / up cut		

**Spezifikation für Fräser**  
**Specifications for Routers**

**620/622/624/626**  
**720/722/724/726**  
**802/803/804/806/809**  
**817/818/826/827/828/836/876**

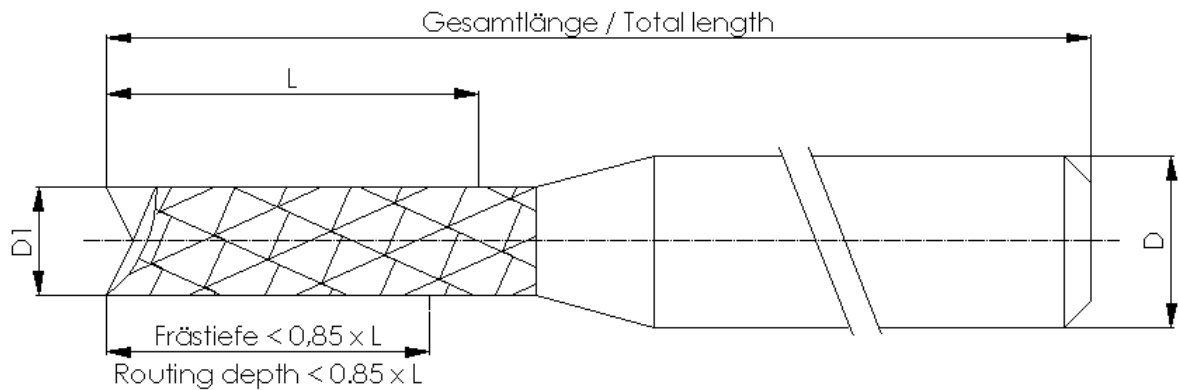

<b>Gesamtlänge / Total Length</b>		<b>38,2 -0,4</b>
<b>Spirallänge / Flute Length</b>	<b>L</b>	<b>+0,6 / -0,1</b>
<b>Schaft- / Shank-Ø</b>	<b>D</b>	<b>-0,001/-0,007</b>
<b>Nenn / Nominal-Ø</b>	<b>D<sub>1</sub></b>	<b>+0,01/-0,02</b>
<b>wenn / if D<sub>1</sub> = D</b>		<b>0/-0,04</b>
<b>Typ / type 836</b>		<b>+0,01/-0,03</b>
<b>Schneidenschaftigkeit / Roughness</b>		<b>≤ 0,006</b>
<b>Ausbrüche / Chip</b>		<b>≤ 0,030 max. 10%</b> <b>der Einzelschneiden eines Fräasers /</b> <b>of the single cutting teeth</b> <b>of a router</b> <small>Angaben / Data in [mm]</small>
<b>Spitzenwinkel / Point Angle</b>	<b>α</b>	<b>±3</b>
<b>Typ / type 802/803/804/806/809</b>		<small>Angaben / Data in [°]</small>

**Typ / Type 802/803/804/806/809:**

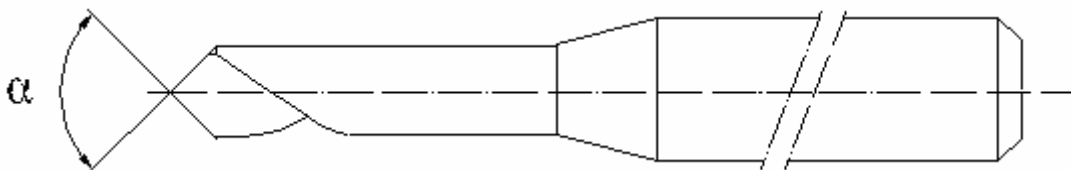

## Application of the Different Type of Routers

different base materials													
Tool Type	description	FR 4		FR 2	CEM 3	CEM 1	PE	PTFE	PMMA	Polyimide	Al	Cu / brass	remark
		oc	ic										
626	diamond cut	~	~	~	~	~							standard contour router
726	chipbreaker	~	~	~	~	~							standard contour router good chip transport and edge quality
817 818	single flute		~	TM	TM	TM	~	~	~	~	~	~	very good edge quality, burr-free and for soft and flexible materials
826 827	2 main cutting lips		~	TM	TM	TM	~	~	~	~	~	~	universal tool for working with plastic and metal
836	3 main cutting lips		~	TM	TM	TM	TM	TM	TM	~	TM	TM	for metallized slots
80X	chamfering and scratching tool	~		~	~	~	~	~	~	~	~	~	good chip transport and edge quality

parameters																						
cutting speed. $v_s$ [m/min]	190-220		160-180		160-180		160-180		100-120		100-120		110-130		100-120		200-250		180-220			
$\varnothing$ [mm]	oc	ic	chip load $[\mu\text{m}/1]$																			
1,0	8	8	10	10	10	10	10	10	20	10	3	3	Cutting speed and chip load are base recommendations depending on the material specifications. The parameters have to be adjusted accordingly									
1,2	12	10	14	14	14	14	14	14	30	14	5	5										
1,6	20	15	25	25	25	25	25	25	40	25	8	8										
2,0	38	30	45	45	45	35	35	50	35	12	12											
2,4	48	34	55	55	55	40	40	60	40	15	15											

**legend:**

optimal material = ~  
possible alternative = TM

ic = inner contour  
oc = outer contour

**formula:**

spindle speed  $n$  [rpm]  
 $n = v_s * 1000 / (3.14 * \varnothing)$

**feed rate  $F$  [m/min]**

$F = f * n$   
 $f = F / n$  [ $\mu\text{m}/\text{rev}$ ]

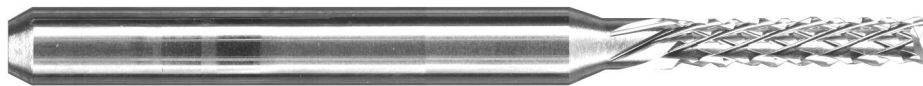

# 626

Fräser aus Hartmetall mit  
Diamantverzahnung  
Anwendungen:

- Standardfräser für  
Innen- und  
Außenkonturen
- alle Basismaterialien  
aus Glasgewebe

Router made of carbide with  
diamond-patterned teeth.  
Applications:

- standard router for inner  
and outer contour
- glass-epoxy based  
materials

# 624

# 620

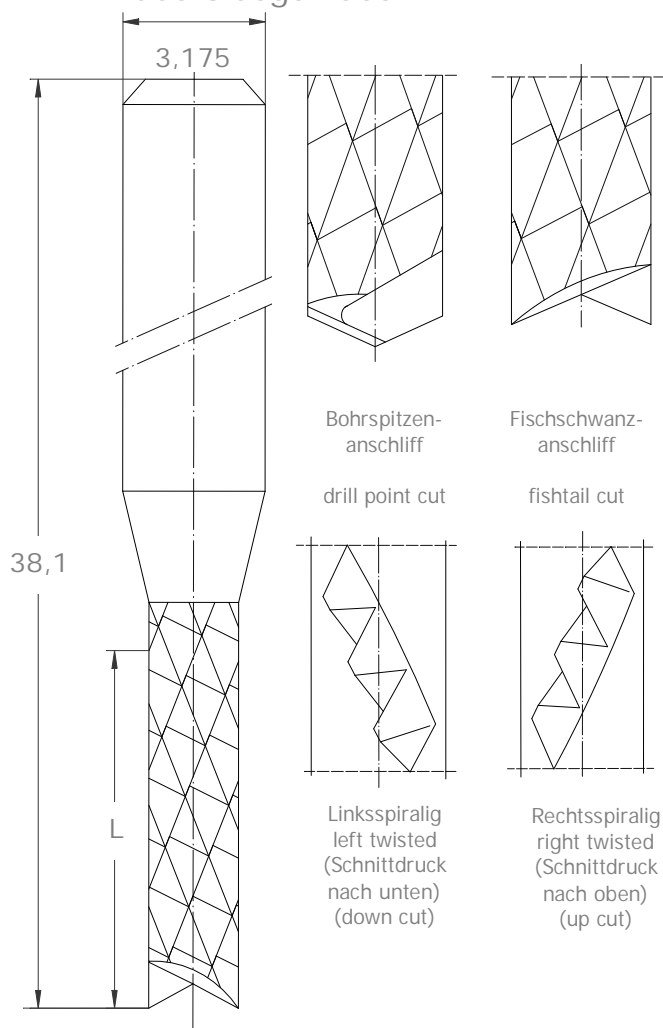

Ø [mm]	L [mm]			Standard
	7,0	8,0	10,0	
1,0	x			626 / 620*
1,1	x			626
1,2	x			626 / 620*
1,3	x			626
1,4	x			626
1,5		x		626
1,6		x		626 / 620*
1,7		x		626
1,8		x		626
1,9		x		626
2,0		x	x	626 / 620*
2,1		x		626
2,2		x		626
2,3		x		626
2,4		x	x	626 / 620*
2,5		x		626
3,0			x*	626
3,175			x*	626

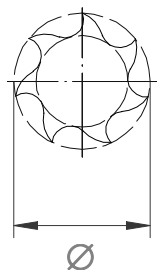

**626** Fischeschwanzanschliff  
rechtsspiralig

fishtail cut  
up cut (right twisted)

**624\*** Bohrspitzenanschliff  
rechtsspiralig

drill point cut  
up cut (right twisted)

**620\*** Fischeschwanzanschliff  
linksspiralig  
\* auf Anfrage

fishtail cut  
down cut (left twisted)  
\* on request

HPTEC GmbH  
Im Karrer 6  
D-88214 Ravensburg  
Germany

Tel.: +49 (0)751-7669-0  
Fax: +49 (0)751-7669-139  
E-Mail: sales@hptec.de  
www.hptec.de

# HPTEC



# 726

# 724

# 720

Fräser aus Vollhartmetall mit Spiralverzahnung

Anwendungen/Vorteile:

- Standardfräser für Innen- und Außenkonturen
- alle Basismaterialien aus Glasgewebe

Router made of solid carbide with spiral-patterned teeth.

Applications/Advantages:

- standard router for inner and outer contour
- all kind of glass-epoxy based materials
- excellent chip transport and surface finish

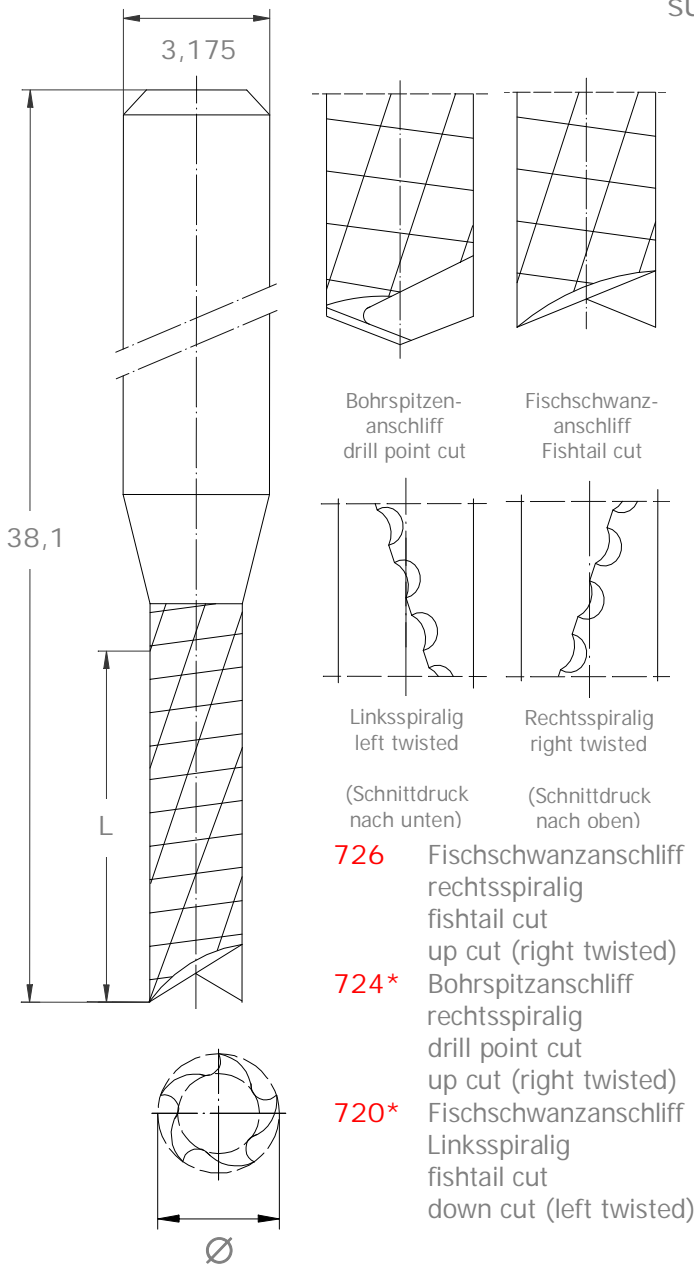

- 726** Fischschwanzanschliff rechtsspiralig  
fishtail cut up cut (right twisted)
- 724\*** Bohrspitzenanschliff rechtsspiralig  
drill point cut up cut (right twisted)
- 720\*** Fischschwanzanschliff Linksspiralig  
fishtail cut down cut (left twisted)

Ø [mm]	L [mm]						Standard
	3	3,5	5,0	7,0	8,5	9,0	
0,5	x						726
0,6	x						726
0,7		x					726
0,8			x				726
0,9			x				726
1,0				x	x*		726 / 724*
1,1				x	x*		726
1,2				x	x*		726 / 724*
1,3				x	x*		726
1,4				x	x*		726
1,5					x		726
1,6					x		726 / 724*
1,7					x		726
1,8					x		726
1,9					x		726
2,0						x	726 / 724*
2,1						x*	726
2,2						x*	726
2,3						x*	726
2,4						x	726 / 724*
2,5						x	726
3,0						x	726
3,175						x	726

\* auf Anfrage \* on request

HPTec GmbH  
Im Karrer 6  
D-88214 Ravensburg  
Germany

Tel.: +49 (0)751-7669-0  
Fax: +49 (0)751-7669-139  
E-Mail: sales@hptec.de  
www.hptec.de

# HPTEC

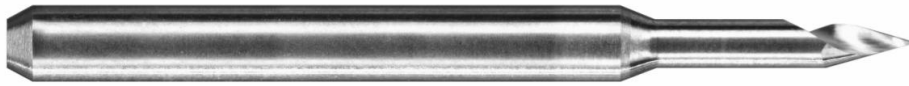

# 802

Frässtichel aus Hartmetall mit einer Spiralnute

Anwendungen:

- Ritzen und Anfasen von Leiterplatten
- Fräsen von Isolationsabständen
- Ritzen von Bruchkanten

V-groove cutter made of carbide with one spiral twisted cut.

Applications:

- chamfering of circuit boards
- routing of dielectric spacing
- scribing of break-out edges

# 803

# 804

# 806

# 809

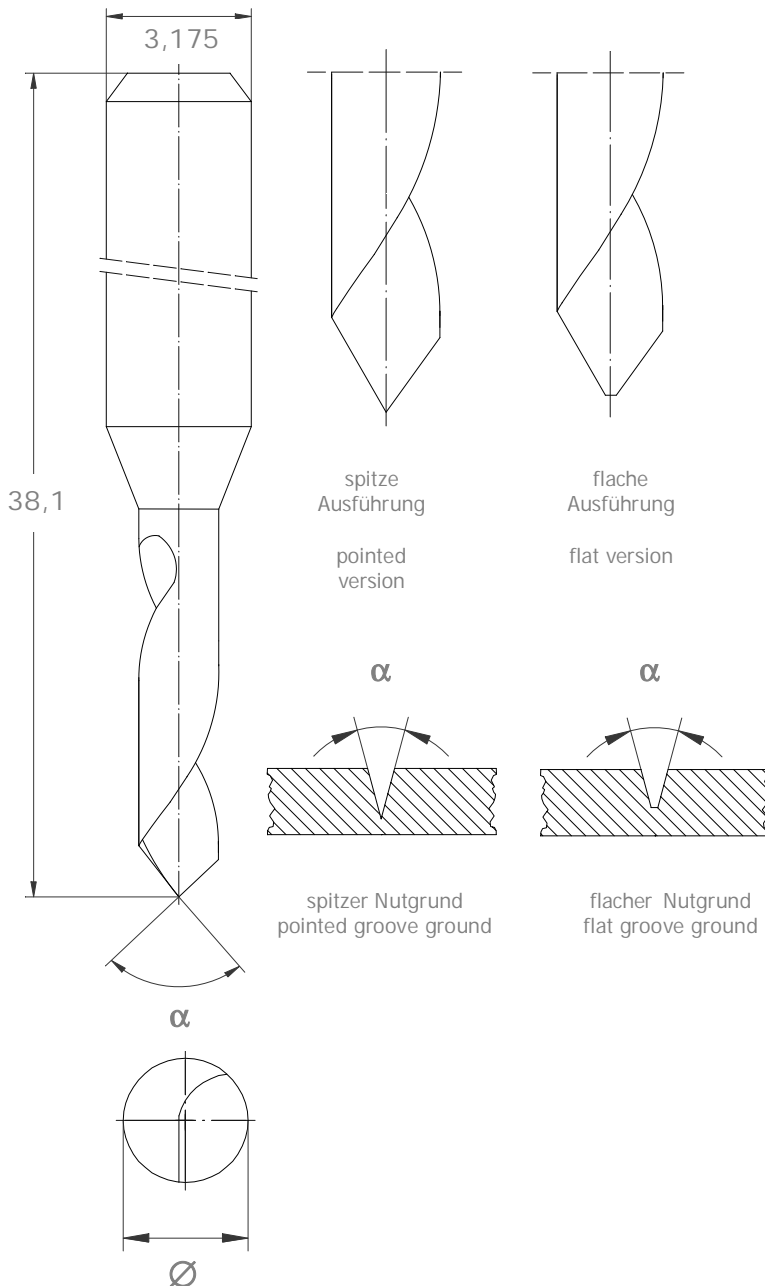

Ø [mm]	α			
	30°	45°	60°	90°
2,0	x	x		
2,4			x	
3,175				x
Standard	802 803	804	806	809

Bemerkung: andere Spitzenwinkel / Durchmesser auf Anfrage  
Remark: other point angles / diameters on request

- 802** 30 ° flache Ausführung  
30 ° flat version
- 803** 30 ° spitze Ausführung  
30 ° pointed version
- 804** 45 ° spitze Ausführung  
45 ° pointed version
- 806** 60 ° spitze Ausführung  
60 ° pointed version
- 809** 90 ° spitze Ausführung  
90 ° pointed version

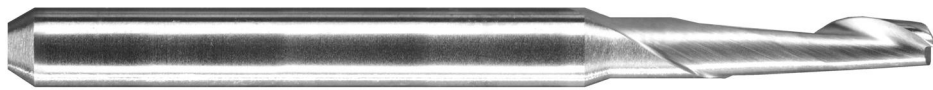

# 818

Fräser aus Hartmetall mit einer Hauptschneide

Anwendungen/Vorteile:

- weiche Kunststoffe, Folien, PE, PTFE, Plexiglas, Polyimid
- Prepregs
- Al, Cu, Messing
- beste Oberflächenqualität

1-Flute router made of carbide.

Application/Advantages:

- soft plastic, foils, PE, PTFE, PMMA, polyimide
- thin prepregs
- Al, Cu, brass
- best surface quality

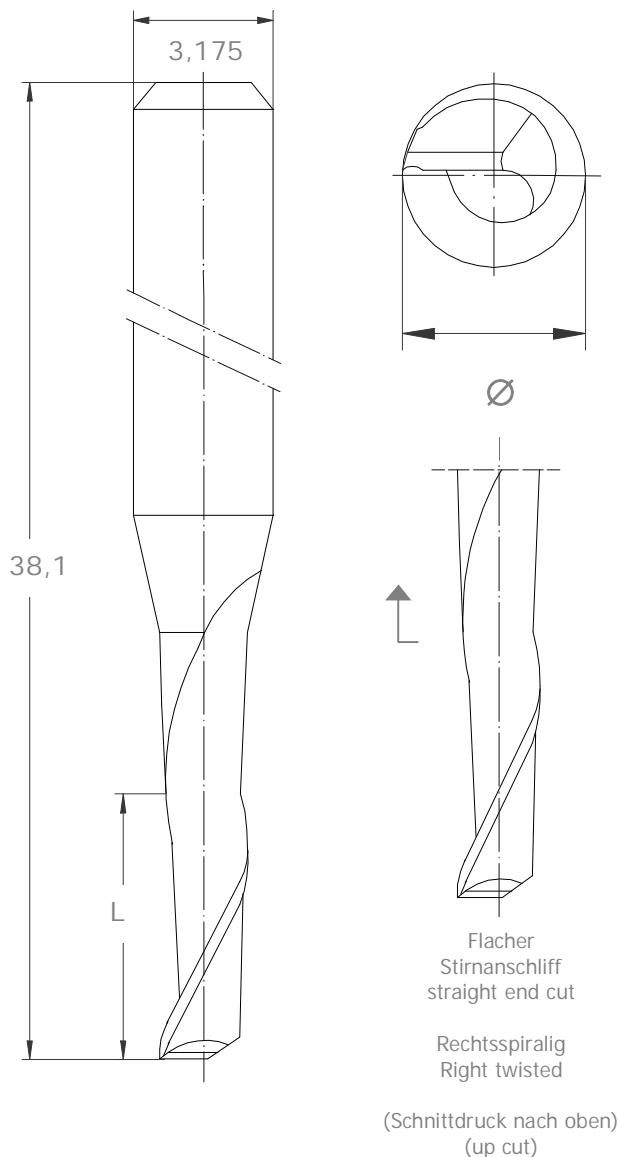

Ø [mm]	L [mm]					
	1,5	3,0	4,0	5,0	8,0	9,0
0,4	x					
0,5		x				
0,6		x				
0,7		x				
0,8		x				
0,9		x				
1,0		x				
1,1		x*				
1,2			x			
1,3			x*			
1,4			x			
1,5			x			
1,6				x		
1,7				x*		
1,8				x*		
1,9				x*		
2,0					x	
2,4					x	
3,0						x
3,175						x*

**818** Flacher Stirnanschliff  
rechtsspiralig (Schnittdruck nach oben)  
flat end cut  
up cut (right twisted)

\* auf Anfrage \* on request

HPTec GmbH  
Im Karrer 6  
D-88214 Ravensburg  
Germany

Tel.: +49 (0)751-7669-0  
Fax: +49 (0)751-7669-139  
E-Mail: sales@hptec.de  
www.hptec.de

# HPTEC

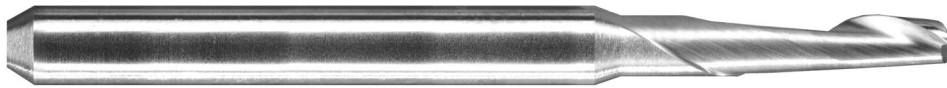

# 817

Fräser aus Hartmetall mit einer Hauptschneide

1-Flute router made of carbide.

Anwendungen/Vorteile:

Application/Advantages:

- für die Leiterplatte
  - weiche Kunststoffe, Folien, PE, PTFE, Plexiglas, Polyimid
  - Prepregs
  - Al, Cu, Messing
  - beste Oberflächenqualität

- Router for PCB
  - soft plastic, foils, PE, PTFE, PMMA, polyimide
  - thin prepregs
  - Al, Cu, brass
  - best surface quality

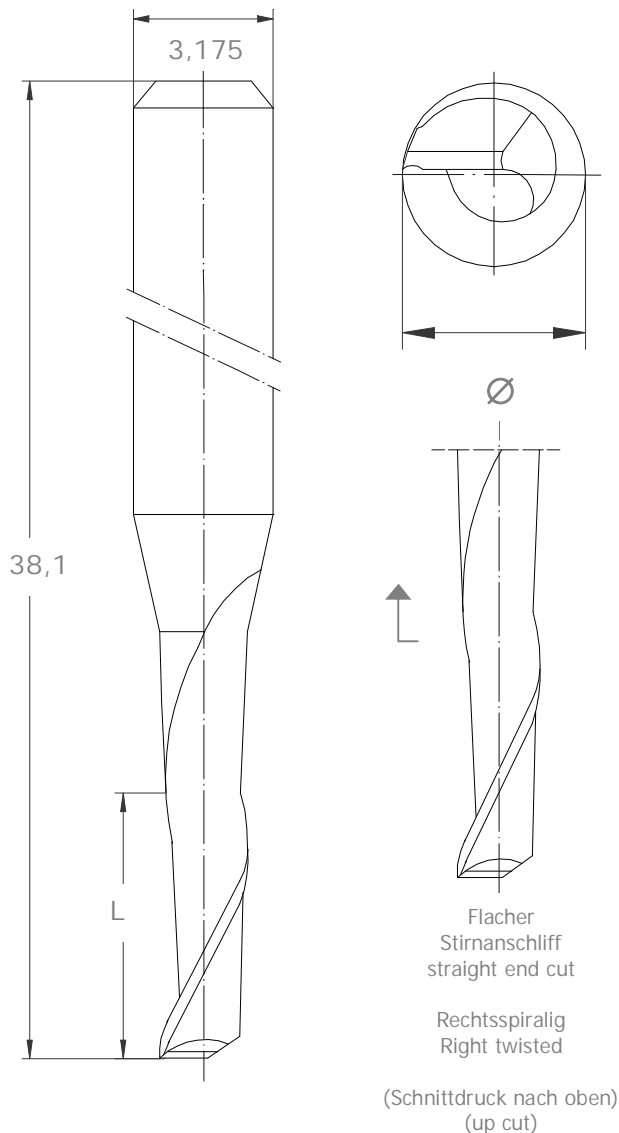

Ø [mm]	L [mm]				
	3,0	4,0	5,0	8,0	9,0
1,0	x				
1,1	x*				
1,2		x			
1,3		x*			
1,4		x*			
1,5		x*			
1,6			x		
1,7			x*		
1,8			x*		
1,9			x*		
2,0				x	
2,4				x	
3,0					x
3,175					x*

\* auf Anfrage \* on request

**817** Flacher Stirnanschliff  
rechtsspiralig (Schnittdruck nach oben)  
flat end cut  
up cut (right twisted)

HPTec GmbH  
Im Karrer 6  
D-88214 Ravensburg  
Germany

Tel.: +49 (0)751-7669-0  
Fax: +49 (0)751-7669-139  
E-Mail: sales@hptec.de  
www.hptec.de

**HPTEC**

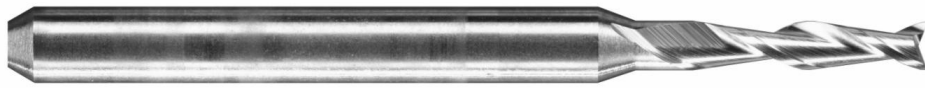

# 826 828

Fräser aus Hartmetall mit  
2 Hauptschneiden

Anwendungen/Vorteile:

- Tiefenfräsungen Typ 828
- Innenkonturen/Schlitzte mit sehr hohen Qualitätsanforderungen
- Kunststoffe und Metalle
- sehr guter Spantransport

2-Flute router made of carbide.

Applications/Advantages:

- depth routing type 828
- inner contour/slots with high quality demands
- routing plastic and metals
- excellent chip transport

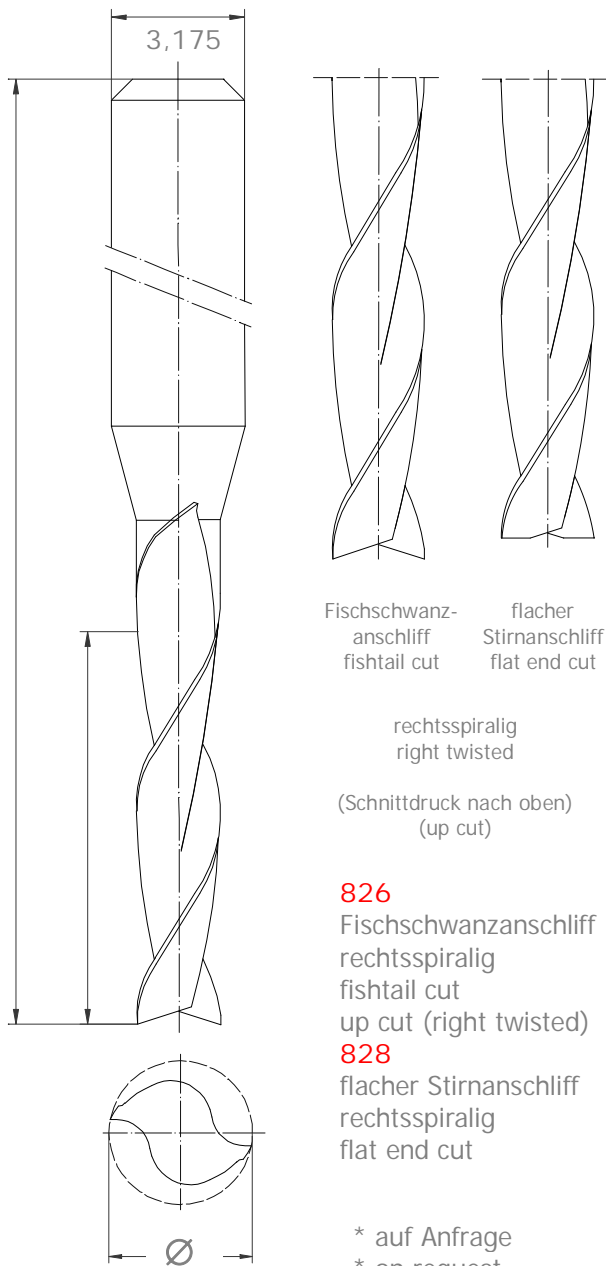

**826**  
Fischschwanzanschliff  
rechtsspiralig  
fishtail cut  
up cut (right twisted)

**828**  
flacher Stirnanschliff  
rechtsspiralig  
flat end cut

\* auf Anfrage  
\* on request

Ø [mm]	L [mm]								
	0,7	1,0	1,5	3,0	5,0	6,0	8,0	10,0	
0,20	x*								
0,25		x*							
0,3		x*							
0,4			x*						
0,5				x					
0,6				x					
0,7				x					
0,8					x				
0,9					x				
1,0					x				
1,1					x				
1,2					x				
1,3					x				
1,4					x				
1,5						x			
1,6						x			
1,7						x			
1,8						x			
1,9						x			
2,0							x		
2,1							x		
2,2							x		
2,3							x		
2,4							x		
2,5							x		
3,0								x	
3,175									x

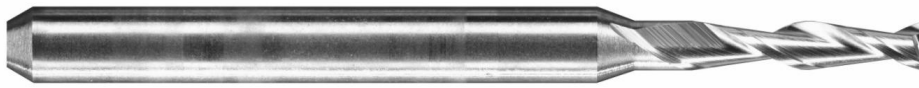

# 827

Fräser aus Hartmetall mit  
2 Hauptschneiden

Anwendungen/Vorteile:

- für die Leiterplatte
  - Tiefenfräsungen
  - Innenkonturen/Schlitze mit sehr hohen Qualitätsanforderungen
  - Kunststoffe und Metalle
  - sehr guter Spantransport

2-Flute router made of carbide.

Applications/Advantages:

- for PCB
  - depth routing type 828
  - inner contour/slots with high quality demands
  - routing plastic and metals
  - excellent chip transport

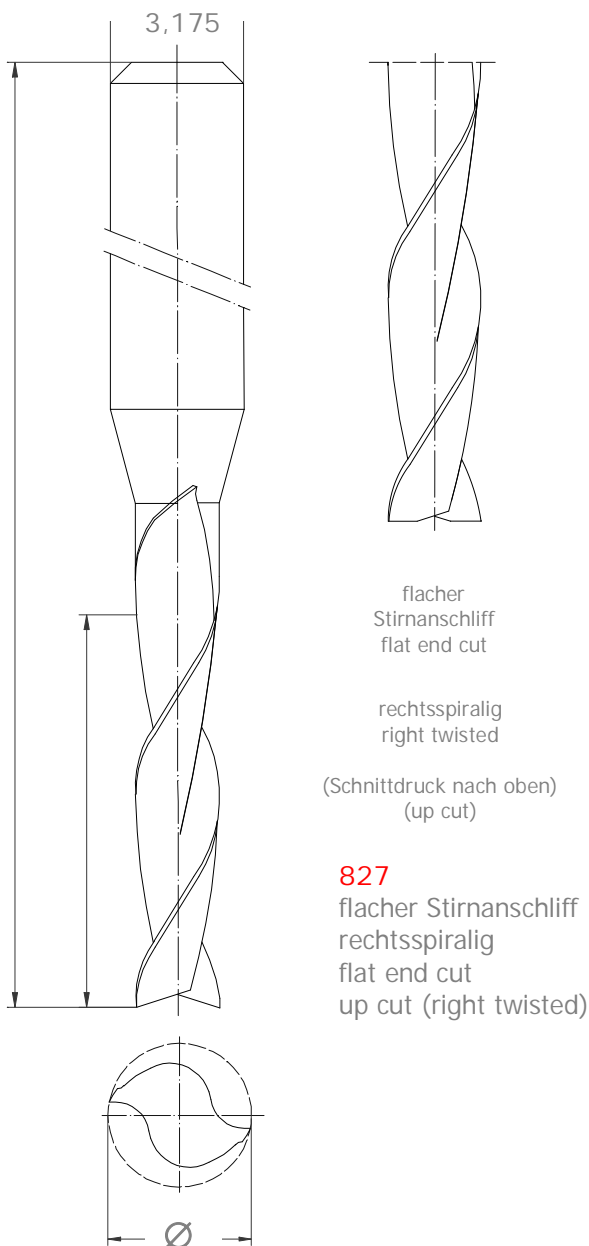

Ø [mm]	L [mm]				
	3,0	5,0	6,0	8,0	10,0
0,6	x*				
0,7	x*				
0,8		x*			
0,9		x*			
1,0		x			
1,1		x*			
1,2		x			
1,3		x*			
1,4		x*			
1,5			x*		
1,6			x		
1,7			x*		
1,8			x*		
1,9			x*		
2,0				x	
2,1				x*	
2,2				x*	
2,3				x*	
2,4				x	
2,5				x*	
3,0					x
3,175					x*

\* auf Anfrage

\* on request

HPTec GmbH  
Im Karrer 6  
D-88214 Ravensburg  
Germany

Tel.: +49 (0)751-7669-0  
Fax: +49 (0)751-7669-139  
E-Mail: sales@hptec.de  
www.hptec.de

# HPTEC

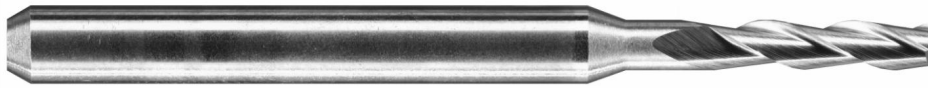

# 836

Fräser aus Hartmetall mit  
3 Hauptschneiden

Anwendungen:

- metallisierte Schlitze
- Fräsen von Metalloberflächen

3-Flute router made of carbide.

Applications:

- routing slots
- routing of metal surfaces

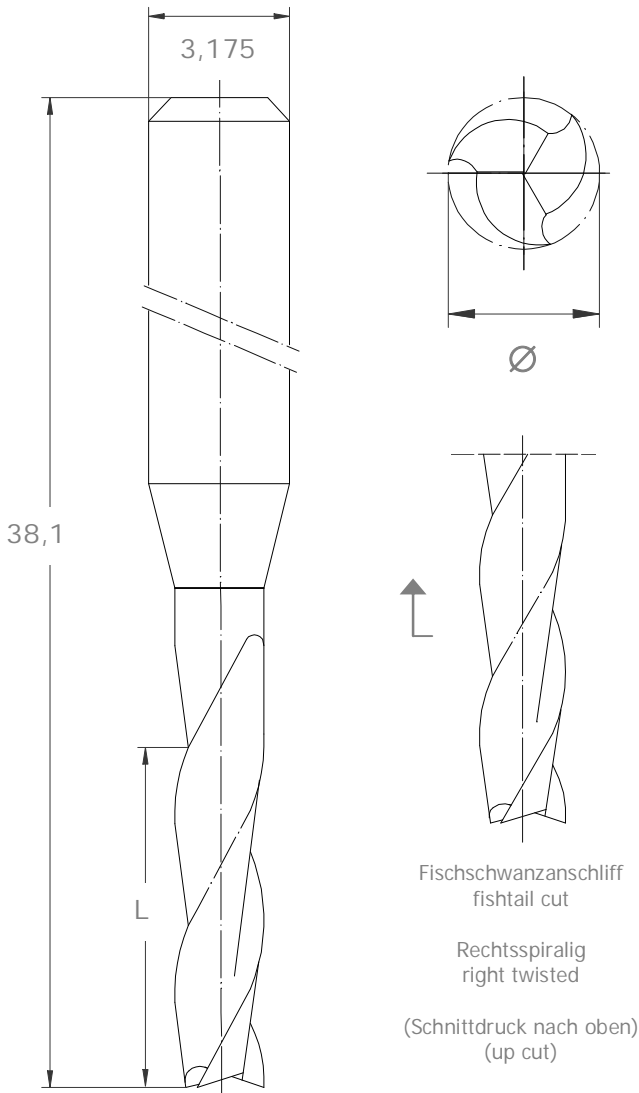

Ø [mm]	L [mm]		
	5,0	7,0	9,0
1,0	x*		
1,1	x*		
1,2	x*		
1,3	x*		
1,4	x*		
1,5		x*	
1,6		x*	
1,7		x*	
1,8		x*	
1,9		x*	
2,0			x*
2,4			x*

\* auf Anfrage \* on request

**836** Fischschwanzanschliff  
Rechtsspiralig  
fishtail cut  
up cut (right twisted)

HPTec GmbH  
Im Karrer 6  
D-88214 Ravensburg  
Germany

Tel.: +49 (0)751-7669-0  
Fax: +49 (0)751-7669-139  
E-Mail: sales@hptec.de  
www.hptec.de

# HPTEC



# 876

Schlichtfräser aus Hartmetall  
Anwendung:

- gratfreies Fräsen von Galvanoanbindungen Goldfinger und Metalloberflächen

Contour finishing router made of carbide.  
Application:

- burr-free routing of metal surfaces (goldfingers) and metal composite laminates

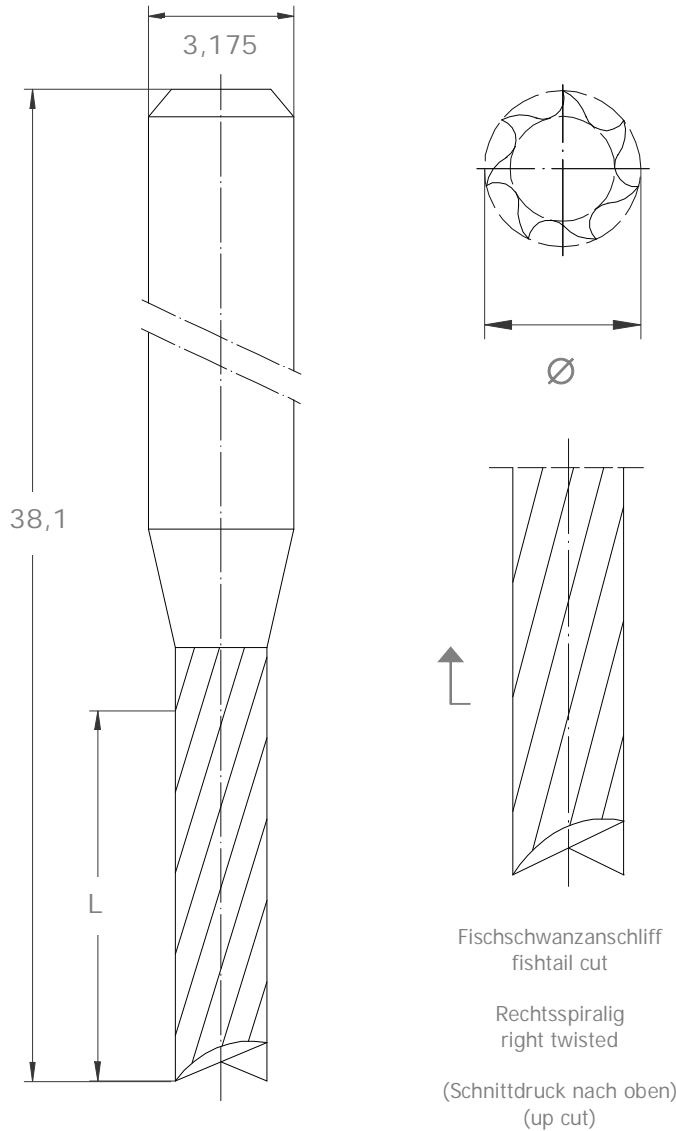

Ø [mm]	L [mm]
	7,0
1,6	x*
2,0	x*
2,4	x*

\* auf Anfrage \* on request

Bemerkung: andere Durchmesser auf Anfrage

Remark: other diameters on request

**876** Fischschwanzanschliff  
rechtsspiralig  
fishtail cut  
up cut (right twisted)

HPTec GmbH  
Im Karrer 6  
D-88214 Ravensburg  
Germany

Tel.: +49 (0)751-7669-0  
Fax: +49 (0)751-7669-139  
E-Mail: sales@hptec.de  
www.hptec.de

**HPTEC**

**Parameter Recommendation for Microdrill Dia. 0.10 - 0.50 mm in FR4**

**HPTec Standard**

Parameter for <sup>1</sup>:

**FR4 ML 4 - 8 layer**

**Different Spindle Types <sup>1</sup>**

Ø (mm)	chip-load (µm/1)	180000 max.		200000 max.		250000 max.		300000 max.		retract feed (m/min)
		spindle speed (rpm)	feed rate (m/min)	spindle speed (rpm)	feed rate (m/min)	spindle speed (rpm)	feed rate (m/min)	spindle speed (rpm)	feed rate (m/min)	
<b>0,10</b>	<b>5</b>	<b>160000</b>	<b>0,8</b>	<b>180000</b>	<b>0,9</b>	<b>250000</b>	<b>1,2</b>	<b>300000</b>	<b>1,4</b>	<b>2,0</b>
<b>0,105</b>	<b>5</b>	<b>160000</b>	<b>0,8</b>	<b>180000</b>	<b>0,9</b>	<b>250000</b>	<b>1,2</b>	<b>300000</b>	<b>1,4</b>	<b>2,0</b>
<b>0,11</b>	<b>6</b>	<b>160000</b>	<b>0,9</b>	<b>180000</b>	<b>1,0</b>	<b>250000</b>	<b>1,4</b>	<b>300000</b>	<b>1,7</b>	<b>2,0</b>
<b>0,12</b>	<b>7</b>	<b>160000</b>	<b>1,2</b>	<b>180000</b>	<b>1,3</b>	<b>250000</b>	<b>1,8</b>	<b>300000</b>	<b>2,2</b>	<b>2,0</b>
<b>0,15</b>	<b>8</b>	<b>160000</b>	<b>1,3</b>	<b>180000</b>	<b>1,4</b>	<b>250000</b>	<b>2,0</b>	<b>300000</b>	<b>2,4</b>	<b>3,0</b>
<b>0,20</b>	<b>11</b>	<b>160000</b>	<b>1,8</b>	<b>180000</b>	<b>2,0</b>	<b>239000</b>	<b>2,7</b>	<b>239000</b>	<b>2,7</b>	<b>4,0</b>
<b>0,25</b>	<b>15</b>	<b>160000</b>	<b>2,4</b>	<b>180000</b>	<b>2,7</b>	<b>191000</b>	<b>2,9</b>	<b>191000</b>	<b>2,9</b>	<b>5,0</b>
<b>0,30</b>	<b>18</b>	<b>160000</b>	<b>2,9</b>	<b>160000</b>	<b>2,9</b>	<b>160000</b>	<b>2,9</b>	<b>160000</b>	<b>2,9</b>	<b>6,0</b>
<b>0,35</b>	<b>21</b>	<b>137000</b>	<b>2,8</b>	<b>137000</b>	<b>2,8</b>	<b>137000</b>	<b>2,8</b>	<b>137000</b>	<b>2,8</b>	<b>7,0</b>
<b>0,40</b>	<b>23</b>	<b>120000</b>	<b>2,8</b>	<b>120000</b>	<b>2,8</b>	<b>120000</b>	<b>2,8</b>	<b>120000</b>	<b>2,8</b>	<b>8,0</b>
<b>0,45</b>	<b>26</b>	<b>107000</b>	<b>2,8</b>	<b>107000</b>	<b>2,8</b>	<b>107000</b>	<b>2,8</b>	<b>107000</b>	<b>2,8</b>	<b>9,0</b>
<b>0,50</b>	<b>30</b>	<b>96000</b>	<b>2,8</b>	<b>96000</b>	<b>2,8</b>	<b>96000</b>	<b>2,8</b>	<b>96000</b>	<b>2,8</b>	<b>10,0</b>

<sup>1</sup> Other materials and spindle speeds on request

# Parameter Recommendation for Drills



Customer	HPTec Standard		
Material <sup>1</sup> :	FR 4 ≤ 6 layers		
Spindle Type:	Air Bearing		
Cutting Speed	$v_s = 150$	[m/min]	
Spindle Speed <sup>1</sup>	$n_{max} = 125000$	[rpm]	

Diameter = D [mm]	Spindle Speed = n [rpm]
Chip Load = f [μm/1]	Retract Feed = R [m/min]
	Infeed = F [m/min]

D	f	F	n	R	D	f	F	n	R
0.10	6	0.8	125000	2.0	2.30	90	1.9	21000	25.0
0.15	10	1.3	125000	3.0	2.35	90	1.8	20000	25.0
0.20	14	1.8	125000	4.0	2.40	90	1.8	20000	25.0
0.25	19	2.4	125000	5.0	2.45	90	1.8	20000	25.0
0.30	23	2.9	125000	6.0	2.50	90	1.8	20000	25.0
0.35	26	3.3	125000	7.0	2.55	90	1.8	20000	25.0
0.40	29	3.5	119000	8.0	2.60	90	1.8	20000	25.0
0.45	33	3.5	106000	9.0	2.65	90	1.8	20000	25.0
0.50	37	3.5	95000	10.0	2.70	90	1.8	20000	25.0
0.55	42	3.7	87000	15.0	2.75	90	1.8	20000	25.0
0.60	46	3.7	80000	20.0	2.80	90	1.8	20000	25.0
0.65	50	3.7	73000	25.0	2.85	90	1.8	20000	25.0
0.70	55	3.7	68000	25.0	2.90	90	1.8	20000	25.0
0.75	60	3.8	64000	25.0	2.95	90	1.8	20000	25.0
0.80	65	3.9	60000	25.0	3.00	90	1.8	20000	25.0
0.85	70	3.9	56000	25.0	3.05	90	1.8	20000	25.0
0.90	75	4.0	53000	25.0	3.10	90	1.8	20000	25.0
0.95	80	4.0	50000	25.0	3.15	90	1.8	20000	25.0
1.00	85	4.1	48000	25.0	3.175	90	1.8	20000	25.0
1.05	90	4.1	45000	25.0	3.20	46	0.9	20000	25.0
1.10	90	3.9	43000	25.0	3.30	46	0.9	20000	25.0
1.15	90	3.8	42000	25.0	3.40	46	0.9	20000	25.0
1.20	90	3.6	40000	25.0	3.50	46	0.9	20000	25.0
1.25	90	3.4	38000	25.0	3.60	46	0.9	20000	25.0
1.30	90	3.3	37000	25.0	3.70	46	0.9	20000	25.0
1.35	90	3.2	35000	25.0	3.80	46	0.9	20000	25.0
1.40	90	3.1	34000	25.0	3.90	46	0.9	20000	25.0
1.45	90	3.0	33000	25.0	4.00	42	0.8	20000	25.0
1.50	90	2.9	32000	25.0	4.10	42	0.8	20000	25.0
1.55	90	2.8	31000	25.0	4.20	42	0.8	20000	25.0
1.60	90	2.7	30000	25.0	4.30	42	0.8	20000	25.0
1.65	90	2.6	29000	25.0	4.40	42	0.8	20000	25.0
1.70	90	2.5	28000	25.0	4.50	42	0.8	20000	25.0
1.75	90	2.4	27000	25.0	4.60	42	0.8	20000	25.0
1.80	90	2.4	27000	25.0	4.70	42	0.8	20000	25.0
1.85	90	2.3	26000	25.0	4.80	42	0.8	20000	25.0
1.90	90	2.3	25000	25.0	4.90	35	0.7	20000	25.0
1.95	90	2.2	24000	25.0	5.00	35	0.7	20000	25.0
2.00	90	2.2	24000	25.0	5.20	35	0.7	20000	25.0
2.05	90	2.1	23000	25.0	5.40	35	0.7	20000	25.0
2.10	90	2.1	23000	25.0	5.60	35	0.7	20000	25.0
2.15	90	2.0	22000	25.0	5.80	35	0.7	20000	25.0
2.20	90	2.0	22000	25.0	6.00	35	0.7	20000	25.0
2.25	90	1.9	21000	25.0	6.50	35	0.7	20000	25.0

<sup>1</sup> other materials and spindle speeds on request

## Parameter Recommendation for Routers



Material<sup>1</sup>: FR4  
 Cutting Speed: Type 626 = 190 m/min Type 726 = 220 m/min  
 Spindle type: Ball Bearing Spindle speed<sup>1</sup> n<sub>max.</sub>= 60000 rpm  
 Tool type: 626 / 726

Diameter = **D** [mm] Spindle speed = **n** [rpm]  
 Chip load = **f** [μm/1] Table feed = **F(XY)** [m/min]  
 Infeed with / without pre-drilling = **F(Z)** [m/min]  
 max. stack height = **H** [mm]

D	f	F (XY)	n		F (Z) without pre-drilling	F (Z) with pre-drilling	H
			type 626	type 726			
[mm]	[μm/1]	[m/min]	rpm	rpm	[m/min]	[m/min]	[mm]
0.80	5	0.3		60000	0.2	0.5	3.5
0.90	6	0.4		60000	0.2	0.5	3.5
1.00	8	0.5	60000	60000	0.4	2.0	5.0
1.10	9	0.5	55000	60000	0.4	2.0	5.0
1.20	10	0.6	50000	58000	0.4	2.0	5.0
1.30	12	0.6	47000	54000	0.6	2.0	5.0
1.40	14	0.7	43000	50000	0.6	2.0	5.0
1.50	16	0.8	40000	47000	0.6	2.0	6.0
1.60	18	0.8	38000	44000	0.8	5.0	6.0
1.70	22	0.9	36000	41000	0.8	5.0	6.0
1.80	26	1.0	34000	39000	0.8	5.0	6.0
1.90	30	1.1	32000	37000	0.8	5.0	6.0
2.00	34	1.2	30000	35000	1.3	5.0	6.5
2.10	38	1.3	29000	33000	1.3	5.0	6.5
2.20	40	1.3	27000	32000	1.3	5.0	6.5
2.30	42	1.3	26000	30000	1.3	5.0	6.5
2.40	44	1.3	25000	29000	1.3	5.0	6.5
2.50	46	1.3	24000	28000	1.3	5.0	6.5
3.00	53	1.2	20000	23000	1.3	5.0	6.5
3.175	55	1.2	20000	22000	1.3	5.0	6.5

<sup>1</sup> other materials and spindle speeds on request

## Parameter Recommendation for Slot Drills



Customer	HPTec Standard	Cutting Speed	$v_s = 150$	[m/min]
Material:	FR 4	Spindle Speed	$n_{max} = 125000$	[rpm]
Spindle Type:	Air Bearing			

Diameter = D [mm]    Spindle Speed = n [rpm]  
 Chip Load = f [ $\mu\text{m}/1$ ]    Infeed = F [m/min]    Retract Feed = R [m/min]

D	f	F	n	R	D	f	F	n	R
0.50	10	1.2	115000	10.0	1.90	76	1.9	25000	25.0
0.55	17	1.8	104000	10.0	1.95	78	1.9	24000	25.0
0.60	20	1.8	88000	15.0	2.00	80	1.9	24000	25.0
0.65	27	2.2	80000	25.0	2.05	80	1.8	23000	25.0
0.70	33	2.5	75000	25.0	2.10	80	1.8	23000	25.0
0.75	35	2.5	70000	25.0	2.15	80	1.8	22000	25.0
0.80	38	2.5	66000	25.0	2.20	80	1.8	22000	25.0
0.85	40	2.5	62000	25.0	2.25	80	1.7	21000	25.0
0.90	43	2.5	58000	25.0	2.30	80	1.7	21000	25.0
0.95	47	2.6	55000	25.0	2.35	80	1.6	20000	25.0
1.00	50	2.6	52000	25.0	2.40	80	1.6	20000	25.0
1.05	52	2.3	45000	25.0	2.45	80	1.6	20000	25.0
1.10	53	2.3	43000	25.0	2.50	80	1.6	20000	25.0
1.15	55	2.3	42000	25.0	2.55	70	1.4	20000	25.0
1.20	56	2.2	40000	25.0	2.60	70	1.4	20000	25.0
1.25	58	2.2	38000	25.0	2.65	70	1.4	20000	25.0
1.30	59	2.2	37000	25.0	2.70	70	1.4	20000	25.0
1.35	61	2.1	35000	25.0	2.75	70	1.4	20000	25.0
1.40	62	2.1	34000	25.0	2.80	70	1.4	20000	25.0
1.45	63	2.1	33000	25.0	2.85	70	1.4	20000	25.0
1.50	64	2.0	32000	25.0	2.90	70	1.4	20000	25.0
1.55	66	2.0	31000	25.0	2.95	70	1.4	20000	25.0
1.60	67	2.0	30000	25.0	3.00	60	1.2	20000	25.0
1.65	68	2.0	29000	25.0	3.05	60	1.2	20000	25.0
1.70	69	1.9	28000	25.0	3.10	60	1.2	20000	25.0
1.75	70	1.9	27000	25.0	3.15	60	1.2	20000	25.0
1.80	72	1.9	27000	25.0	3.175	60	1.2	20000	25.0
1.85	74	1.9	26000	25.0					

## Formula for Cutting Parameters

Cutting Speed  $v_s$ :

$$V_s = \frac{n * D * \pi}{1000}$$

$v_s$  = cutting speed [m/min]

$n$  = spindle speed [rpm]

$D$  = nominal diameter [mm]

$\pi$  = 3,14

Chip load  $f$ :

(Feed per revolution)

$$f = \frac{F * 1000}{n}$$

$f$  = chip load [mm/rev.]

$F$  = feed rate [m/min]

$n$  = spindle speed [1/min]

**Conversion formula:**

Feed rate  $F$ :

$$F = \frac{f * n}{1000}$$

Spindle speed  $n$ :

$$n = \frac{V_s}{D * \pi} * 1000$$

**Example:**

Given data: cutting speed  $v_s$ : 150 m/min  
chip load  $f$ : 0,055 mm/rev  
diameter  $D$ : 0,7 mm

$$\Rightarrow \text{spindle speed } n = \frac{150 \text{ m/min}}{(0,7 \text{ mm} * 3,14)} * 1000 = 68243 \text{ rpm}$$

$\Rightarrow$  chosen spindle speed:  **$n = 68000 \text{ rpm}$**

$$\Rightarrow \text{feed rate } F = \frac{(0,055 \text{ mm/rev} * 68000 \text{ rpm})}{1000} = 3,74 \text{ m/min}$$

$\Rightarrow$  chosen feed rate:  **$F = 3,7 \text{ m/min}$**

## Trouble Shooting

### Trouble shooting when drilling printed circuit boards:

Problem	Possible Causes	Remedy
drill breakage	<ul style="list-style-type: none"> <li>- chips jam in flute space</li> <li>- cutting pressure too high</li> <li>- spindle run-out error</li> <li>- dirty/defect collet</li> <li>- drill deviation</li> <li>- chipping on cutting edges</li> </ul>	<ul style="list-style-type: none"> <li>- use drills suitable for the specific cutting conditions (geometry), check extraction system/ parameters</li> <li>- adapt feed rate</li> <li>- check spindle run-out</li> <li>- clean/replace collet</li> <li>- minimising of drill deviation</li> <li>- ensure correct tool handling</li> </ul>
inaccurate drill hole positioning (drill deviation)	<ul style="list-style-type: none"> <li>- flute length too long</li> <li>- spindle run-out error</li> <li>- dirty/defect collet</li> <li>- pin hole inaccurate</li> <li>- drill wear too high or chipping on cutting edges</li> </ul>	<ul style="list-style-type: none"> <li>- adapt flute length</li> <li>- check spindle run-out</li> <li>- clean/replace collet</li> <li>- check pin hole</li> <li>- reduce hit counts/ no. of regrinding operations, check cutting conditions, check tool handling</li> </ul>
poor surface quality of hole wall	<ul style="list-style-type: none"> <li>- smear caused by inefficient chip removal</li> <li>- drill wear too high or chipping on cutting edges</li> <li>- board material insufficiently hardened</li> </ul>	<ul style="list-style-type: none"> <li>- improve chip removal by               <ul style="list-style-type: none"> <li>a) improved extraction system</li> <li>b) use tools with suitable geometry (spade type drills)</li> <li>c) modification of parameters</li> </ul> </li> <li>- reduce hit counts/ no. of regrinding operations, check cutting conditions, check tool handling</li> <li>- check quality of the laminate (multilayer pressing conditions)</li> </ul>
nail heading	<ul style="list-style-type: none"> <li>- feed rate/retraction rate too high or too low</li> <li>- wrong cutting parameters</li> <li>- drill wear too high or chipping on cutting edges</li> <li>- dwell time of drill at cusp too long</li> </ul>	<ul style="list-style-type: none"> <li>- adapt feed rate/retraction rate</li> <li>- adapt cutting conditions to the laminate used</li> <li>- reduce hit count/ no. of regrinding operations, check cutting conditions, check tool handling</li> <li>- reduce dwell time</li> </ul>

## Trouble Shooting

Problem	Possible Causes	Remedy
smear of resin	<ul style="list-style-type: none"> <li>- excessive drilling temperatures</li> <li>- laminate insufficiently hardened</li> <li>- drill wear too high or chipping on cutting edges</li> <li>- insufficient de-smear process</li> </ul>	<ul style="list-style-type: none"> <li>- increase feed rate, reduce cutting speed</li> <li>- check laminate</li> <li>- reduce hit count/ no. of regrinding operations, check cutting conditions, check tool handling</li> <li>- check de-smear process</li> </ul>
burr on entry and/or exit side	<ul style="list-style-type: none"> <li>- drill wear too high or chipping on cutting edges</li> <li>- feed rate/retraction rate too high</li> <li>- entry/backup material too soft</li> <li>- pressure foot power insufficient</li> </ul>	<ul style="list-style-type: none"> <li>- reduce hit count, check cutting conditions, check tool handling</li> <li>- reduce feed rate/retraction rate</li> <li>- use harder entry/backup material</li> <li>- check pressure and correct operation of pressure foot</li> </ul>
contamination on the entry and/or exit side	<ul style="list-style-type: none"> <li>- wrong cutting parameters</li> <li>- drill wear too high or chipping on cutting edges</li> <li>- pressure foot power insufficient</li> <li>- entry/backup material too soft</li> <li>- poor laminate bond</li> </ul>	<ul style="list-style-type: none"> <li>- use recommended parameters</li> <li>- reduce hit count/ no. of regrinding operations, check cutting conditions, check tool handling</li> <li>- increase pressure foot power</li> <li>- use harder entry/backup material</li> <li>- check pressing procedure</li> </ul>
deformation of inner layers	<ul style="list-style-type: none"> <li>- chips jam in flute space</li> <li>- drill wear too high or chipping on cutting edges</li> <li>- poor laminate bond</li> </ul>	<ul style="list-style-type: none"> <li>- use drills suitable for the specific cutting conditions (geometry), check extraction system/ parameters</li> <li>- reduce hit count/no. of regrinding operations, check cutting conditions, check tool handling</li> <li>- check pressing procedure</li> </ul>
winding of chips on drill	<ul style="list-style-type: none"> <li>- insufficient chip extraction</li> <li>- feed rate too low (chips get too long)</li> </ul>	<ul style="list-style-type: none"> <li>- clean and check extraction system, if necessary use more powerful extraction system</li> <li>- increase feed rate</li> </ul>